

DX Series Equipment Monitoring Package

1
Features and
System Configuration

2
Operating Procedure

A
Appendices

User's Manual

Precautions for Correct Use

If you are using the package, please make sure to update to the latest version of both the package and the DX1 unit.

You can obtain the package files from the license portal below and upload them to the Data Flow Controller to use the package.

<https://license-user.automation.omron.com/>

For detailed upload instructions, please refer to the dashboard generator manual, section "2-4 Installation Procedures for Non-Pre-installed Packages."

For details on updating the DX1 unit version, please contact your OMRON sales representative.

NOTE

1. All rights reserved. No part of this publication may be reproduced, stored in a retrieval system, or transmitted, in any form, or by any means, mechanical, electronic, photocopying, recording, or otherwise, without the prior written permission of OMRON.
2. No patent liability is assumed with respect to the use of the information contained herein. Moreover, because OMRON is constantly striving to improve its high-quality products, the information contained in this manual is subject to change without notice.
3. Every precaution has been taken in the preparation of this manual. Nevertheless, OMRON assumes no responsibility for errors or omissions. Neither is any liability assumed for damages resulting from the use of the information contained in this publication.

Trademarks

- ODVA, CIP, CompoNet, DeviceNet, and EtherNet/IP are trademarks of ODVA.
- The SD and SDHC logos are trademarks of SD-3C, LLC. 
- SpeedBee Synapse is a trademark of SALTYSTER Co., Ltd.
- Grafana is a trademark of Grafana Labs.

Copyrights

- This product incorporates certain third party software. The license and copyright information associated with this software is available at https://www.fa.omron.co.jp/product/tool/dx-info/index_en.html.

Introduction

Thank you for purchasing our DX-series Data Flow Controller.

This manual provides information about the Condition Monitoring Package included with the DX Series Data Flow Controller.

Please read this manual and make sure that you understand the functionality and performance of the product before you attempt to use it in a control system.

Intended Audience

This manual is intended for the following personnel, who must also have knowledge of electrical systems (electrical engineers or the equivalent).

- Personnel in charge of designing and operating data utilization systems on a production site.
- Personnel in charge of designing and operating maintenance systems on a production site.

Guidance for Reading This Manual

For information on **Terms and Conditions Agreement**, **Precautions for Safe Use**, **Precautions for Correct Use**, and **Related Manuals**, refer to the *DX Series Data Flow Controller User's Manual (V241-E1)*.

Revision History

A manual revision code appears as a suffix to the catalog number on the front and back covers of the manual.

Cat. No. N701-E1-03

↑
Revision code

Revision code	Date	Revised content
01	October 2025	Original production
02	October 2025	Corrected mistakes
03	May 2026	Added chapter 2-4 Method for Outputting KPIs of the Equipment Monitoring Package

Sections in this Manual

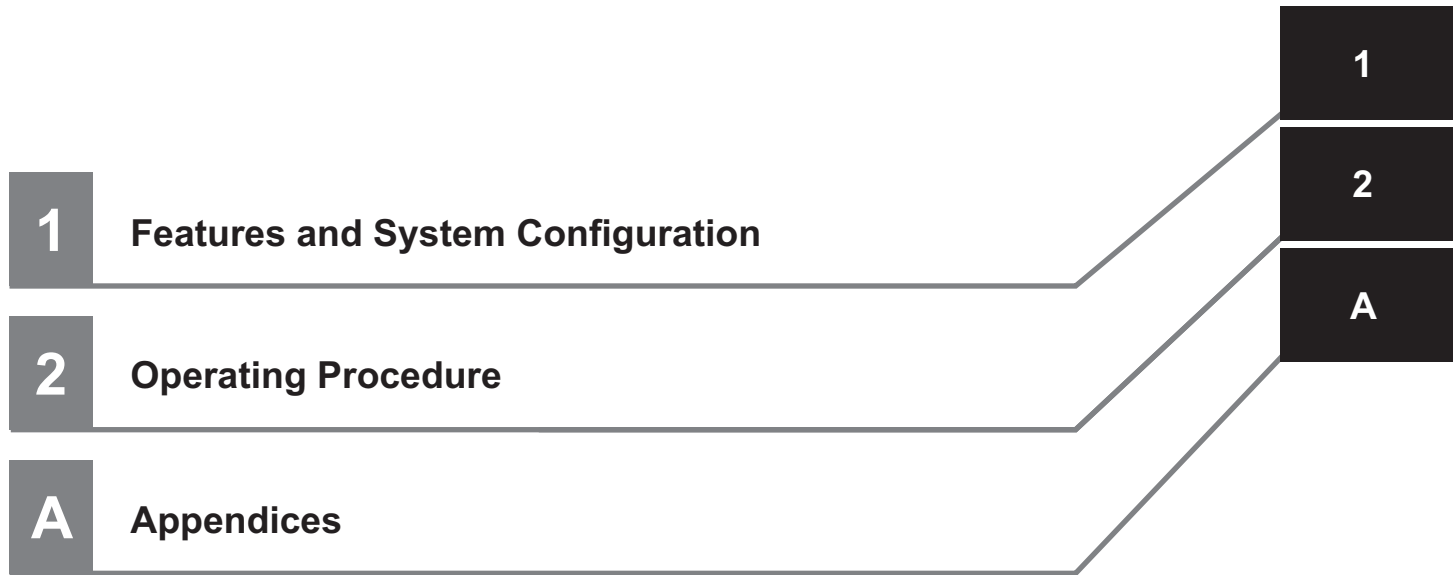

CONTENTS

Introduction	1
Intended Audience.....	1
Guidance for Reading This Manual	1
Revision History	2
Sections in this Manual	3

Section 1 Features and System Configuration

1-1 Capabilities of the Equipment Monitoring Package	1-2
1-2 Example System Configurations	1-3
1-3 Expected Process Types.....	1-5
1-3-1 Continuous Transfer Process.....	1-5
1-3-2 Stepwise Transfer Process	1-5
1-3-3 Cyclic Operation Process.....	1-5

Section 2 Operating Procedure

2-1 Overall Workflow	2-2
2-2 Starting the Equipment Monitoring Package	2-3
2-2-1 Configuration Procedure: System configuration.....	2-3
2-3 Threshold Configuration for Equipment Monitoring Package	2-18
2-4 Method for Outputting KPIs of the Equipment Monitoring Package	2-21

Appendices

A-1 KPI Calculation Method	A-2
---	------------



1

Features and System Configuration

This section describes the features and system configuration of the Equipment Monitoring Package.

1-1	Capabilities of the Equipment Monitoring Package	1-2
1-2	Example System Configurations	1-3
1-3	Expected Process Types	1-5
1-3-1	Continuous Transfer Process	1-5
1-3-2	Stepwise Transfer Process	1-5
1-3-3	Cyclic Operation Process	1-5

1-1 Capabilities of the Equipment Monitoring Package

● Equipment Monitoring Package

This package calculates and visualizes 11 types of factory KPIs for each piece of equipment by measuring the flow of production work after installing the specified sensors.

The KPIs include: OEE (Overall Equipment Effectiveness), Performance Rate, Utilization Rate, Good Product Rate, Actual Cycle Time, Performance Loss Time, Stop Time, Abnormal Time, Production Quantity, Good Product Quantity, Throughput

Additionally, metadata such as factory name, line name, process name, and equipment name can be associated and registered.

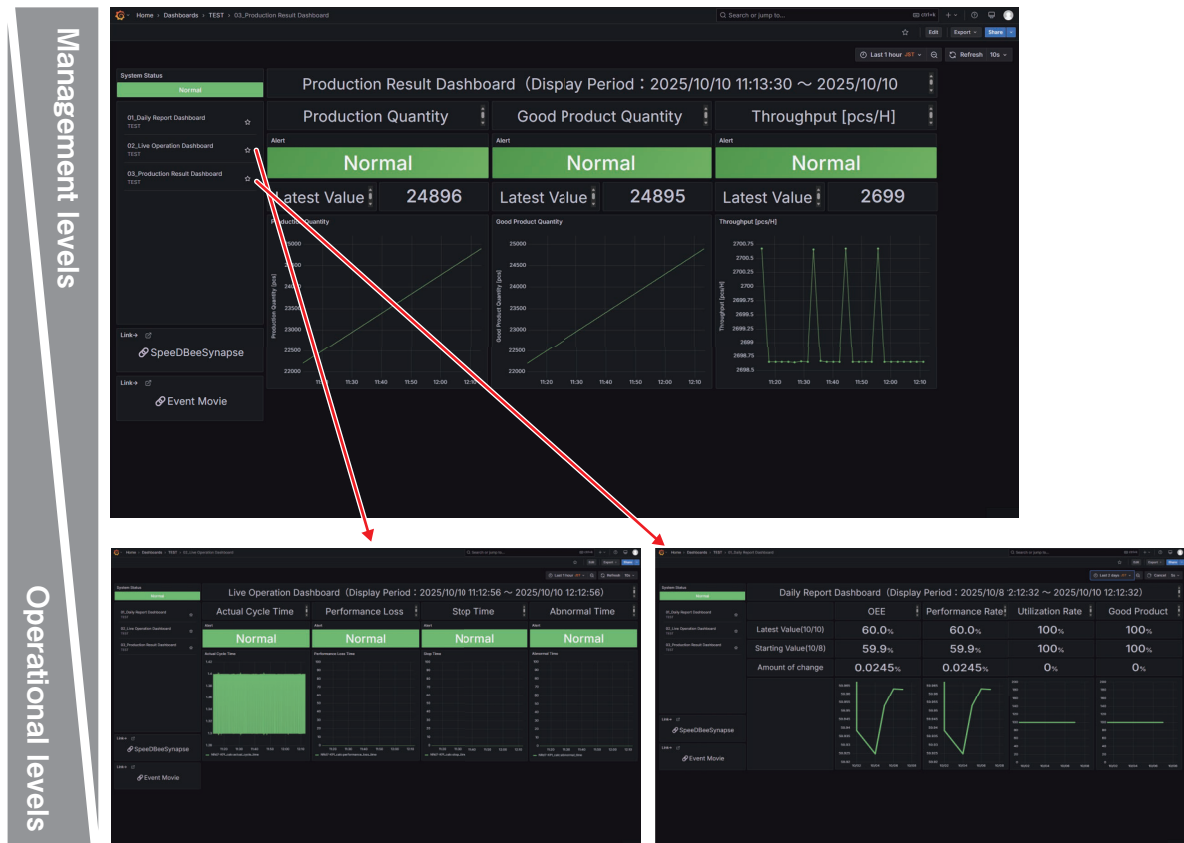

● Workflow

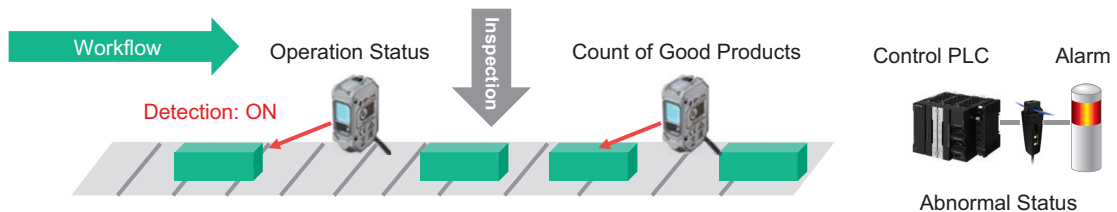

KPI is calculated based on actual data from Operation Status, Abnormal Status, and Good Product Count.

For details on KPI calculation, refer to *A-1 KPI Calculation Method* on page A-2.

1-2 Example System Configurations

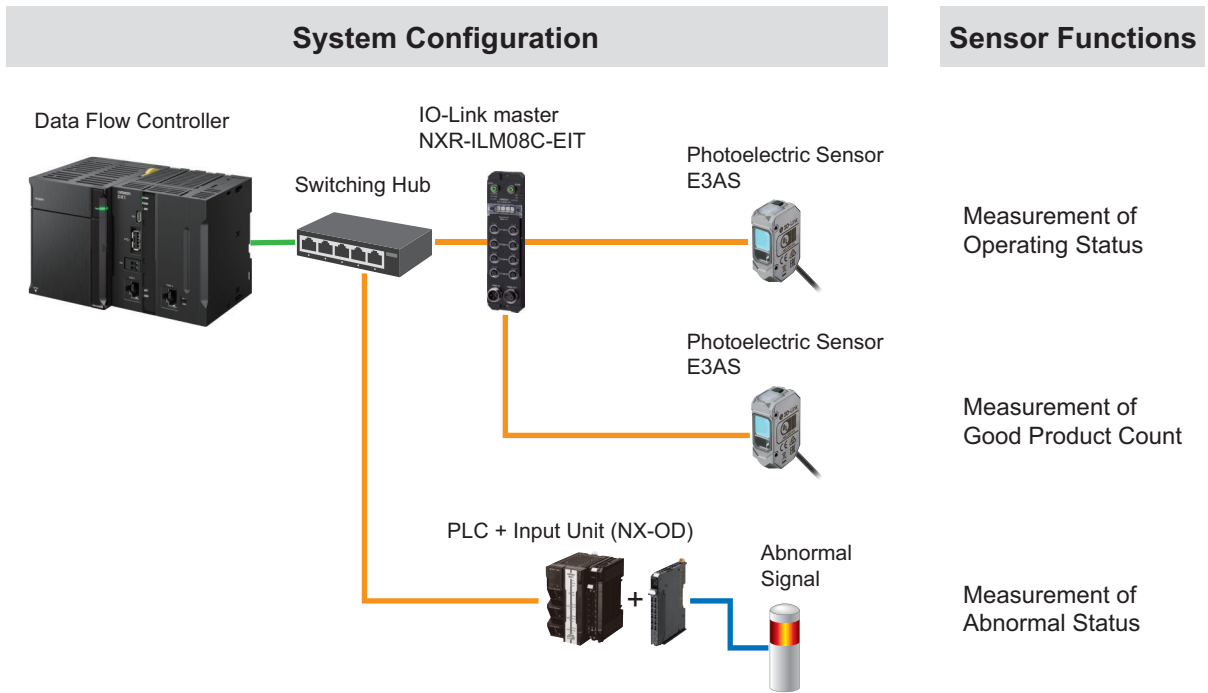

Utilization and Configuration of NXR-ILM08C-EIT

In this package, the NXR-ILM08C-EIT is used as the IO-Link master.

If the Data Flow Controller and the IO-Link master NXR-ILM08C-EIT are on the same subnet, the Dashboard Generator's "IO-Link Master Auto Configuration Function" automatically configures the IO-Link master to communicate with IO-Link devices by obtaining information from the photoelectric sensor E3AS connected to the NXR-ILM08C-EIT.

The Ethernet communication connector (PORT1) of the Data Flow Controller and the IO-Link master NXR-ILM08C-EIT are, by default, set to different IP addresses within the same subnet at the time of factory shipment.

Therefore, immediately after purchasing the devices, you can use the Equipment Monitoring Package simply by connecting the devices, without the need for network configuration.

If the Ethernet communication connector (PORT1) of the Data Flow Controller and the subnet of the IO-Link master NXR-ILM08C-EIT are different, you can change the IP address of the NXR-ILM08C-EIT by switching its hardware switch, allowing you to match the subnet without using a dedicated tool.

Handling of Non-Specified Devices

- Non-specified IO-Link masters, IO-Link devices, and digital I/O devices are not supported. However, by selecting appropriate devices using the Dashboard Generator and registering this package, it is possible to adjust data extraction and processing using default components to match the output specifications of the target device, based on the CIP object array retrieved by the SpeedBee Synapse EIP Collector. To ensure smooth integration, design the output to conform to the input specifications (column structure and data types) expected by the KPI calculation component (KPI_calc). Refer to the official documentation for instructions on using SpeedBee Synapse.
- The IO-Link Master Auto Configuration function is not available for non-specified IO-Link masters. Use the dedicated configuration tools provided by the master vendor for initial setup. When connecting digital I/O devices to the NXR-ILM08C-EIT, automatic configuration is not supported. However, manual port configuration can be performed via the Device Management screen in the Dashboard Generator.
- Configure the PLC output to turn ON (1) when an abnormality occurs.

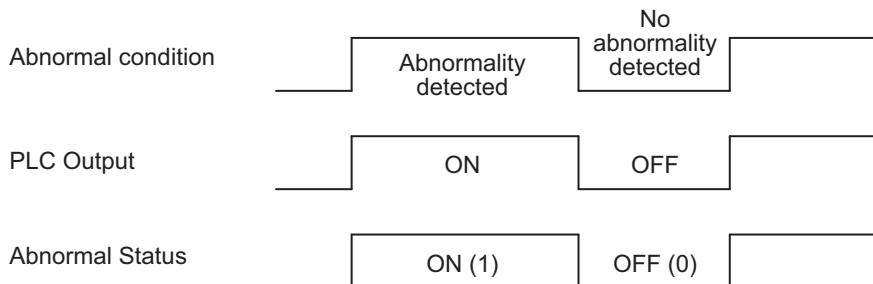

1-3 Expected Process Types

The Equipment Monitoring Package supports the following three example process types:

1-3-1 Continuous Transfer Process

A process in which workpieces are transported at a constant speed. (Example: Belt conveyor)

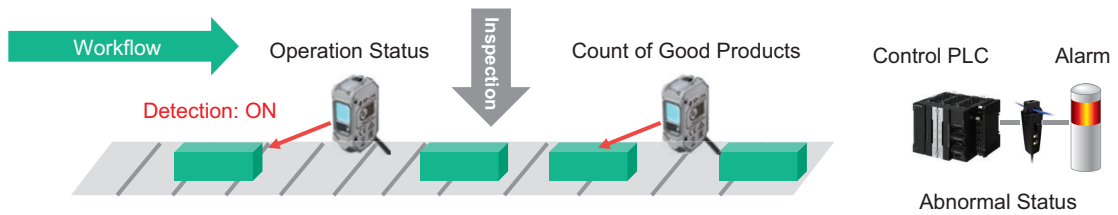

1-3-2 Stepwise Transfer Process

A process in which workpieces repeatedly stop and move at regular intervals. (Example: Linear guide, index table)

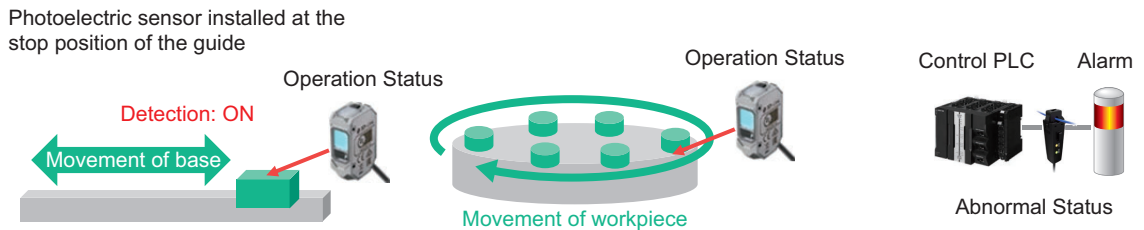

1-3-3 Cyclic Operation Process

A process involving repeated cycles of machining, inspection, or assembly. (Example: Press, drill, pick-and-place)

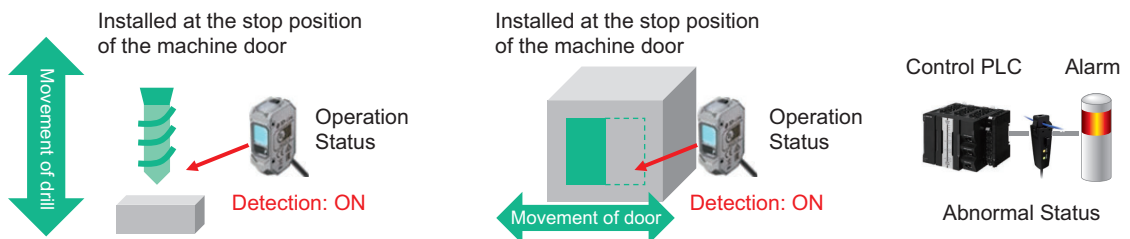

2

Operating Procedure

This section describes the operating procedure for the Equipment Monitoring Package.

2-1 Overall Workflow	2-2
2-2 Starting the Equipment Monitoring Package	2-3
2-2-1 Configuration Procedure: System configuration	2-3
2-3 Threshold Configuration for Equipment Monitoring Package	2-18
2-4 Method for Outputting KPIs of the Equipment Monitoring Package	2-21

2-1 Overall Workflow

The following is the overall workflow for using the Equipment Monitoring Package.

Refer to the manuals or instruction manuals of each device for wiring, installation, configuration, and software startup procedures.

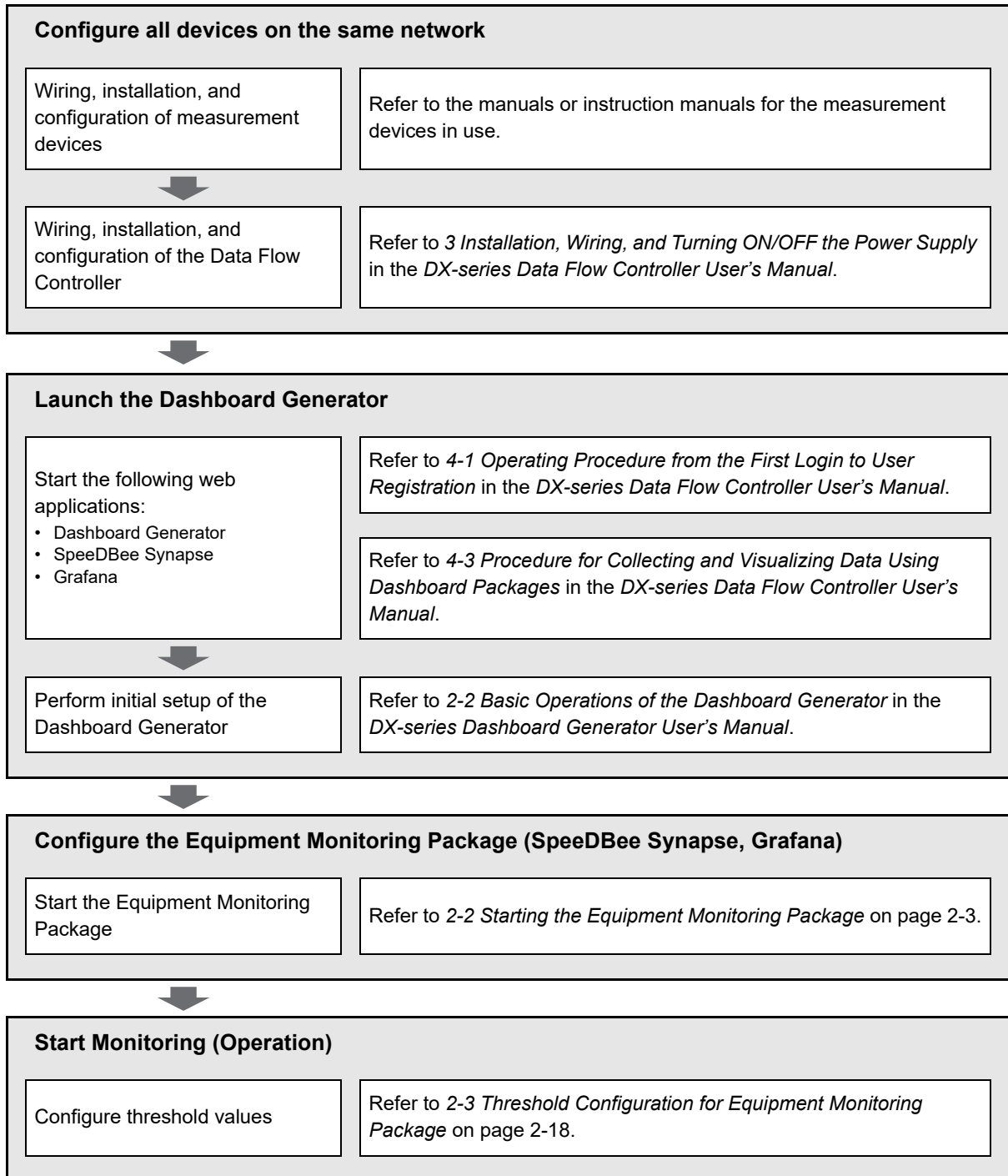

2-2 Starting the Equipment Monitoring Package

For procedures from logging into the Dashboard Generator to applying settings to SpeedBee Synapse and Grafana, refer to *Section 2-2 “Using the Dashboard Generator”* in the *DX Series Dashboard Generator User's Manual*.

2-2-1 Configuration Procedure: System configuration

Follow the steps below.

This procedure assumes that the Dashboard Generator, Synapse, and Grafana are already integrated.

Configuration Steps	Details
NX-OD (Output Unit) Configuration	This section explains the setup based on a system where abnormal status signals are output from the control PLC to an alarm device. In this example, the NX-OD is used as the output unit of the control PLC. Define the NX-OD variables as global variables in Sysmac Studio, and publish them to the network. This is necessary to link the abnormal status signals to the Data Flow Controller.
Device List Screen Configuration	Perform a device scan to retrieve information about devices connected via the Equipment Monitoring Package.
Package List Screen Configuration	Select the Equipment Monitoring Package and specify the equipment identification information and the device to be used for dashboard registration. Register the dashboard based on the specified settings.
Dashboard List Screen Configuration (Synapse / Grafana)	Launch Synapse and start the Error Manager. Launch the Grafana dashboard (graph view).

* The configuration procedures for the Package List screen and the Dashboard List screen are the same as those in *section 2-2-1 Configuration Procedure: System configuration*.

NX-OD (Output Unit) Configuration

Basic configuration of the NX Series Machine Automation Controller is omitted in this explanation.

This section describes how to add variables in the I/O Map settings for NX-OD.

If the variable name for the abnormal status used to control the alarm device in an existing PLC is already known, and the variable is configured as a global variable with network exposure enabled, the following steps are not required.

- 1 In Sysmac Studio, display the I/O Map of the NX-OD that outputs the abnormal status signal.

Switch to offline mode to edit.

2 Confirm the **Variable Name** and **Edit Type** for the abnormal status output.

In this example, it is assumed that the abnormal status signal is output to output contact 00. The variable name is set to **Ch1Output**, and the variable type is set to **Global Variable**.

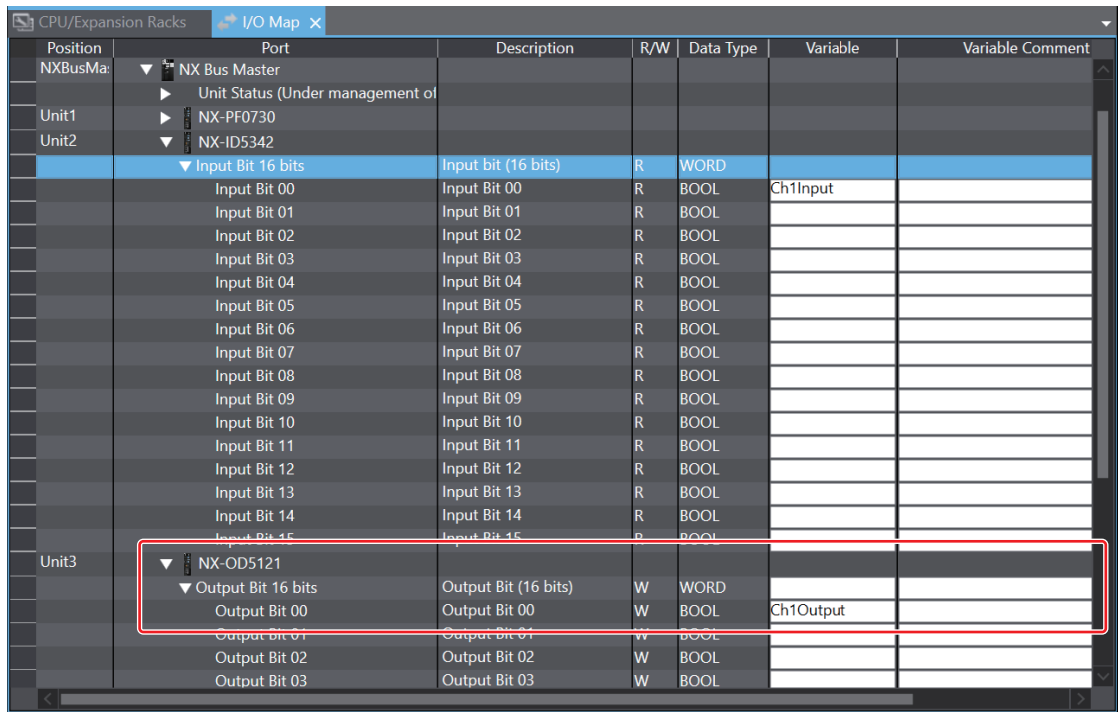

3 Set the network exposure of the abnormal status output variable **Ch1Output** to **Publish Only**.

Open the settings screen from the left tab: **Programming** → **Data** → **Global Variables**.

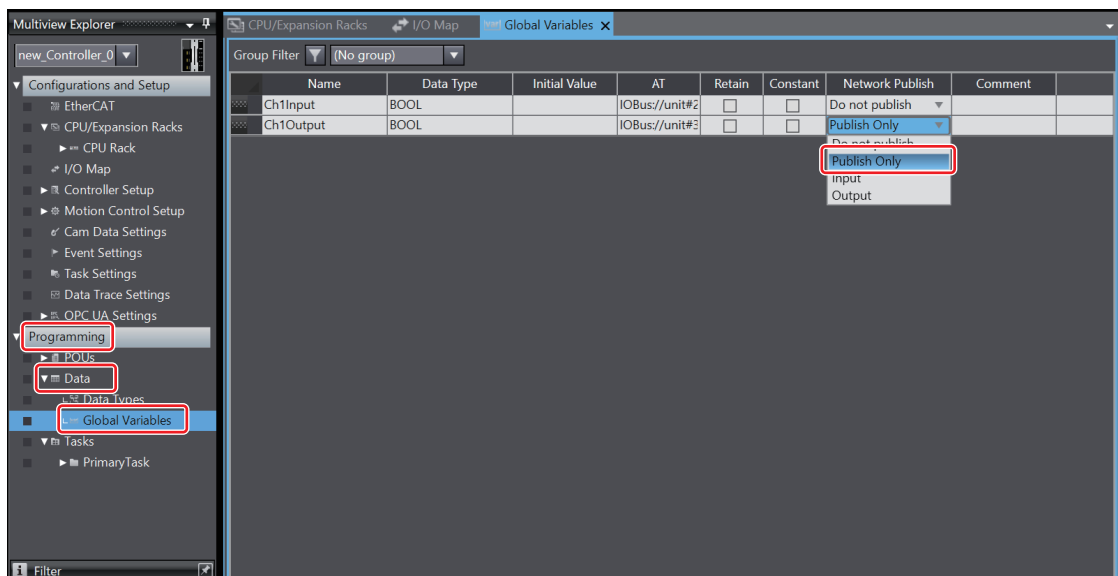

4 Switch to online mode and synchronize.

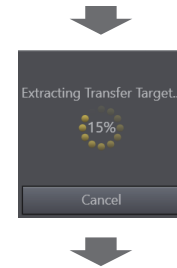
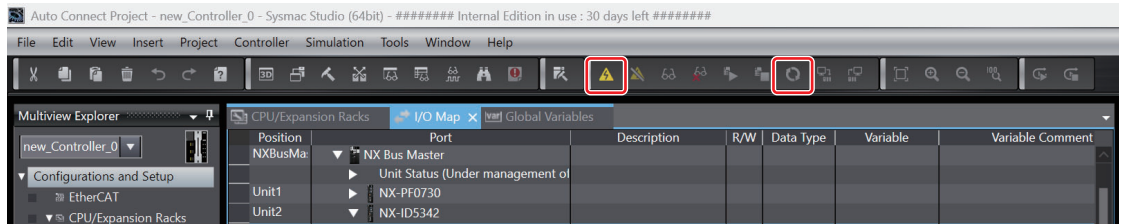

5 Click the **Transfer to Controller** Button.

The program will be transferred.

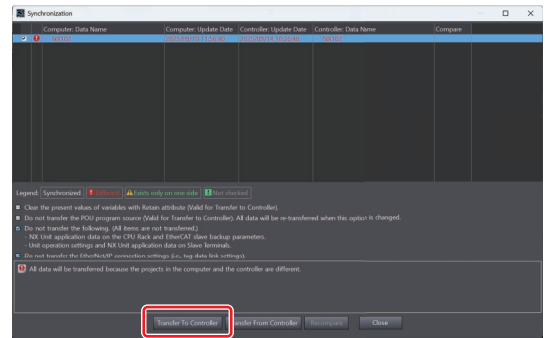
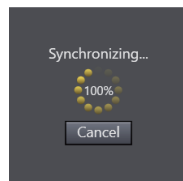

6 When prompted to switch to run mode, click the **Yes** Button.

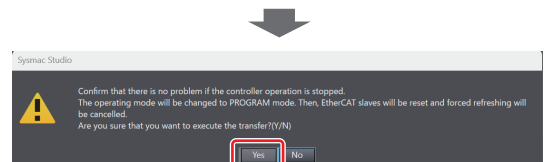

Device List Screen - Device Scan

1 Click the **Device Scan** Button at the top right of the *Device List* Screen.

The *Device Scan* Screen will appear.

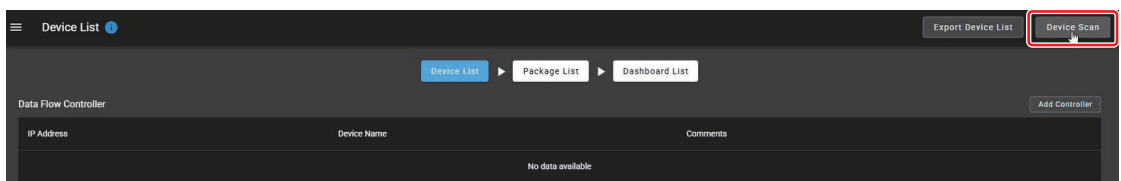

2 Select the interface from the dropdown menu.

3 When the **Scan** Button becomes active, click it.

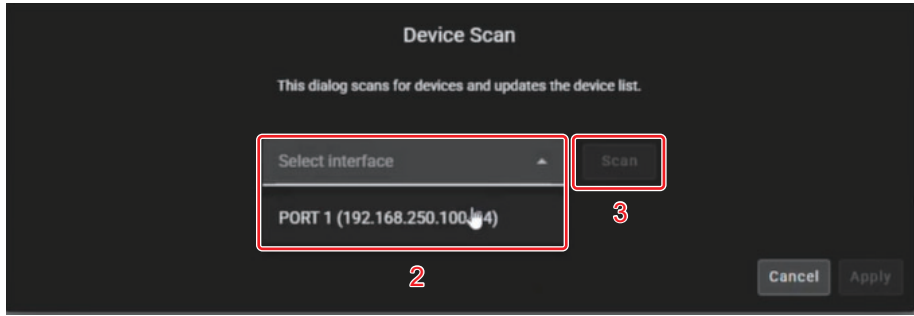

4 The scanned devices will be displayed. Click the **Apply** Button.

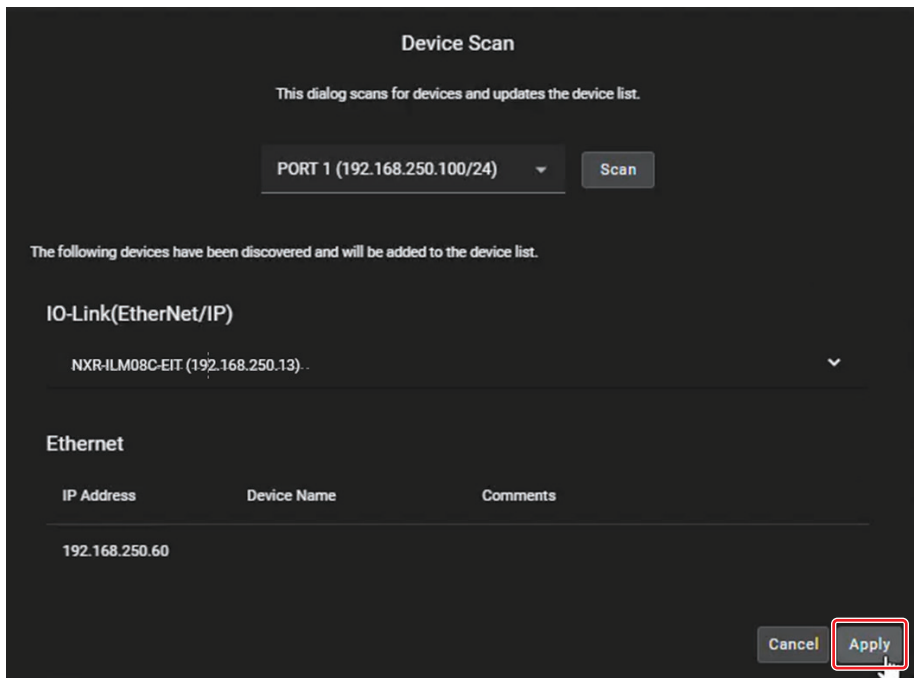

You will return to the *Device List Screen*. Confirm that the devices have been updated. In the example, **NX102-9000** is added to **Ethernet/IP**. Additionally, **NXR-ILM08C-EIT (192.168.250.2)** is added to **IO-Link (Ethernet/IP)**.

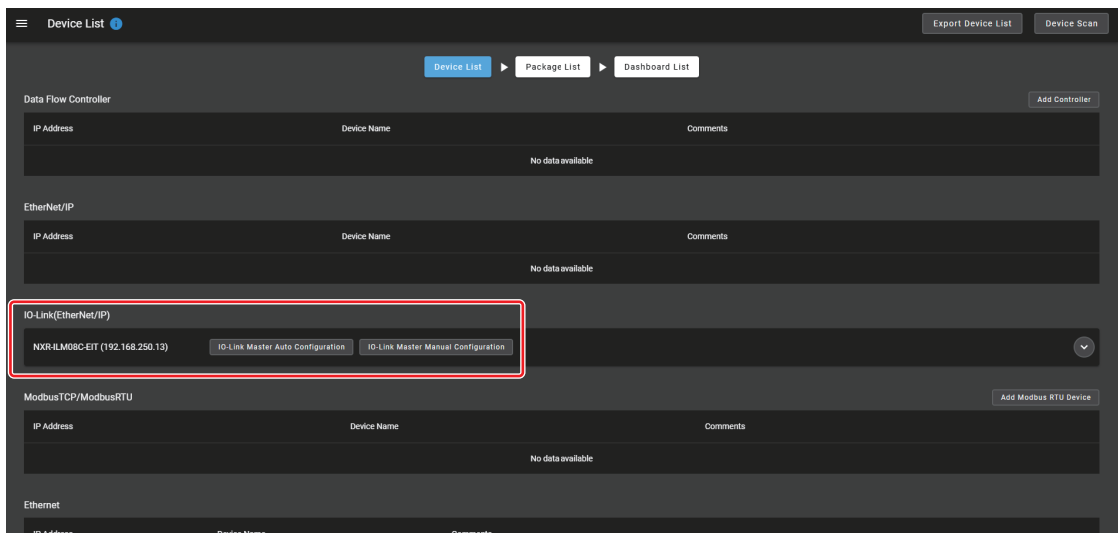

- 5** Click the **IO-Link Master Auto Configuration** Button.

The photoelectric sensor E3AS will be registered.
This can be confirmed in Step 11.

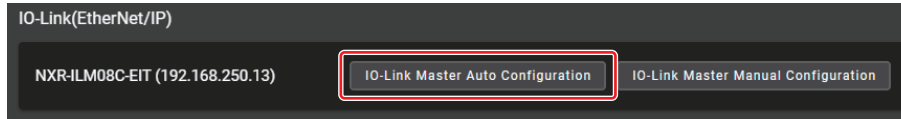

- 6** Click the **Apply** Button.

The update process takes approximately 10 seconds.

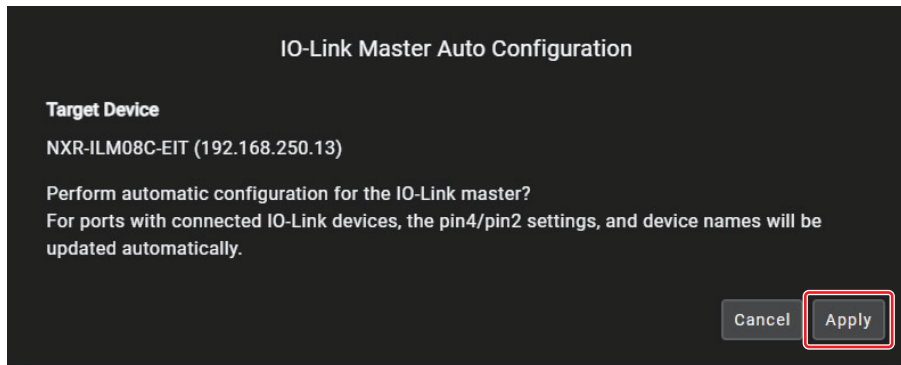

Package List Screen - Dashboard Registration

- 1 Click the **Register Dashboard** Button at the top right of the *Package List* Screen.

The *Register Dashboard* Screen will appear.

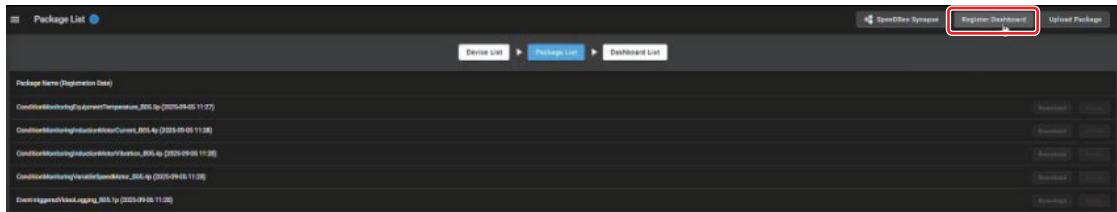

- 2 Configure the information on the *Register Dashboard* Screen.

Setting Item	Description
Dashboard Name	Enter a desired name. It will be displayed in Synapse and Grafana. Example: <i>TEST</i>
Package	Select Equipment Monitoring Package .
Equipment Identification	Optional input fields. Includes factory name, line name, process name, and equipment name.

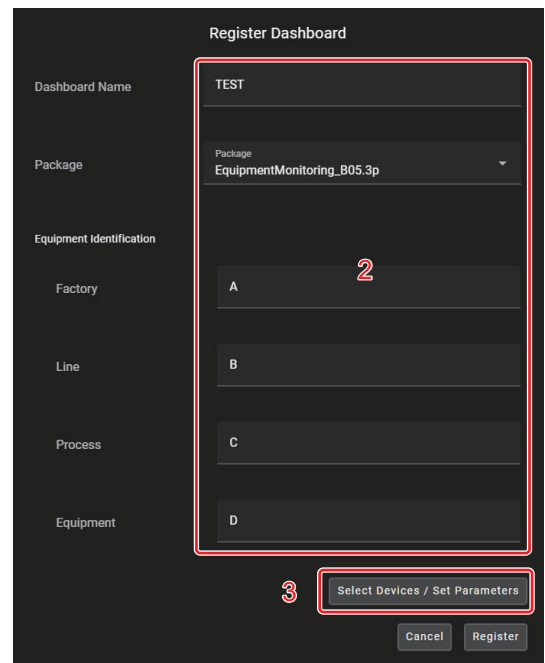

- 3 When the **Select Devices / Set Parameters** Button becomes active, click it.

The *Select Devices / Set Parameters* Screen will appear.

4 Enter the settings used for calculating each KPI.

KPI Display	Settings and Descriptions
KPI_calc_daily	Planned Downtime [min]: Time to stop while power remains on. Example: Lunch break
	UTC Offset: Enter the time difference from UTC.
KPI_calc	Standard Cycle Time [s]: Working time for one workpiece.
	Stop Detection Threshold L (L * Standard Cycle Time): Setting value to determine when workpiece is not coming in.
	Throughput Calc Unit N (Time Taken For N Unit): Setting value for calculating throughput.
	UTC Offset: Enter the time difference from UTC.

For detailed explanations of the above settings, refer to *A-1 KPI Calculation Method* on page A-2.

KPI Display	Settings and Descriptions
NXR_extract	Operation Measurement Sensor Type: You can specify Photoelectric Sensor E3AS or Digital I/O Device.
	Operation Measurement Sensor: Select Port 1 to Port 8
	Abnormality Measurement Sensor Type: You can specify Photoelectric Sensor E3AS or Digital I/O Device.
	Abnormality Measurement Sensor: Select None, Port 1 to Port 8
	Good Product Count Sensor Type: *1 You can specify Photoelectric Sensor E3AS or Digital I/O Device.
	Good Product Count Sensor: *1 Select Port 1 to Port 8

- *1 Even when not using the Good Product Count Sensor, please select "Photoelectric Sensor E3AS" for Good Product Count Sensor Type and select the "Port" where the Operation Measurement Sensor is connected.
This setting is required to correctly calculate OEE.

5 From the **Device** dropdown menu, select **NXR-ILM08C-EIT (IP: 192.168.250.2)**.

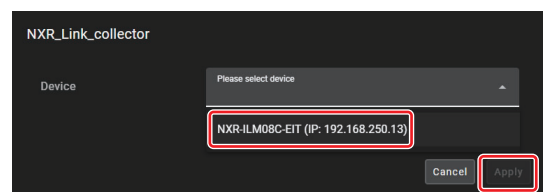
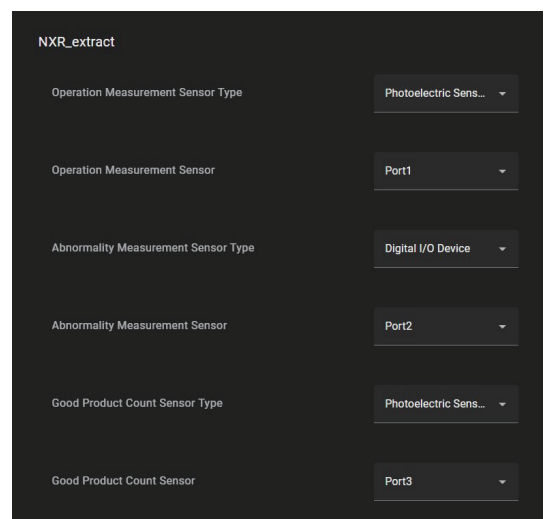
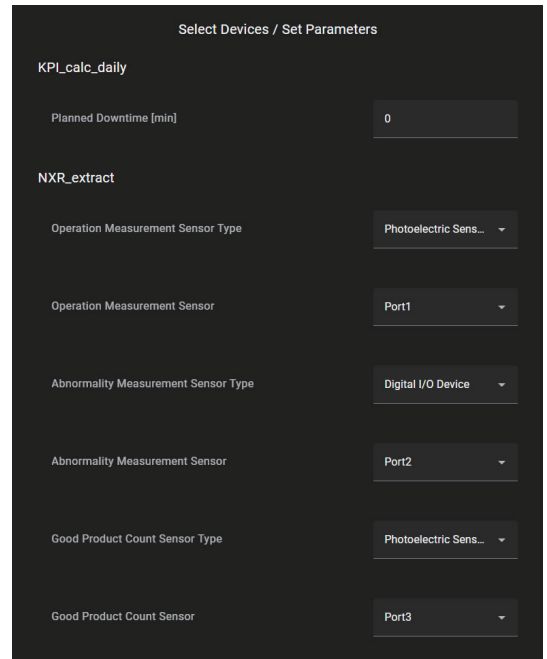

6 Click the **Apply** Button.

You will return to the *Register Dashboard Screen*.

7 Click the **Register** Button.

The Confirm *Dashboard Registration Screen* will appear.

Register Dashboard

Dashboard Name	TEST
Package	Package EquipmentMonitoring_B05.3p
Equipment Identification	
Factory	A
Line	B
Process	C
Equipment	D

Select Devices / Set Parameters

Cancel Register

8 Click the **Register** Button.

Dashboard registration takes approximately 30 seconds.

Once registration is complete, the system will transition to the *Dashboard List Screen*.

Confirm Dashboard Registration

Register the dashboard with the following information? The dashboard name cannot be changed after registration.

Basic Information	
Dashboard Name	TEST
Package	EquipmentMonitoring_B05.3p
Equipment Identification	
Factory	A
Line	B
Process	C
Equipment	D

Cancel Register

Dashboard List Screen - Launching Synapse

- 1 Click the **SpeedBee Synapse** Button at the top right of the *Dashboard List Screen*.

The *SpeedBee Synapse Screen* will appear.

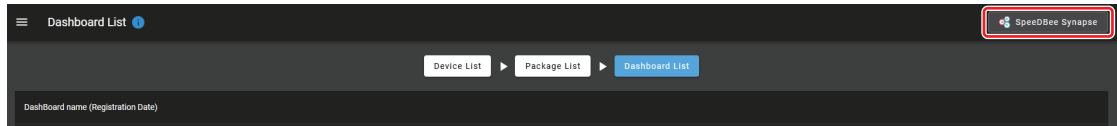

- 2 A panel has been added with a custom dashboard name (e.g., TEST). Click **DETAIL** on the corresponding panel.

The screen will transition to the *Synapse Connection Screen*.

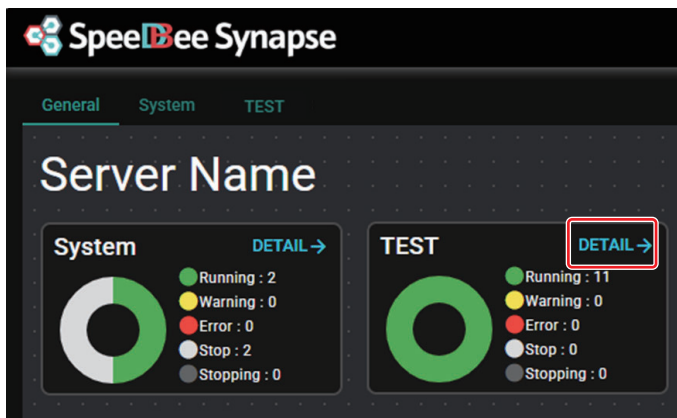

- 3 Change **Run** to **Edit**.

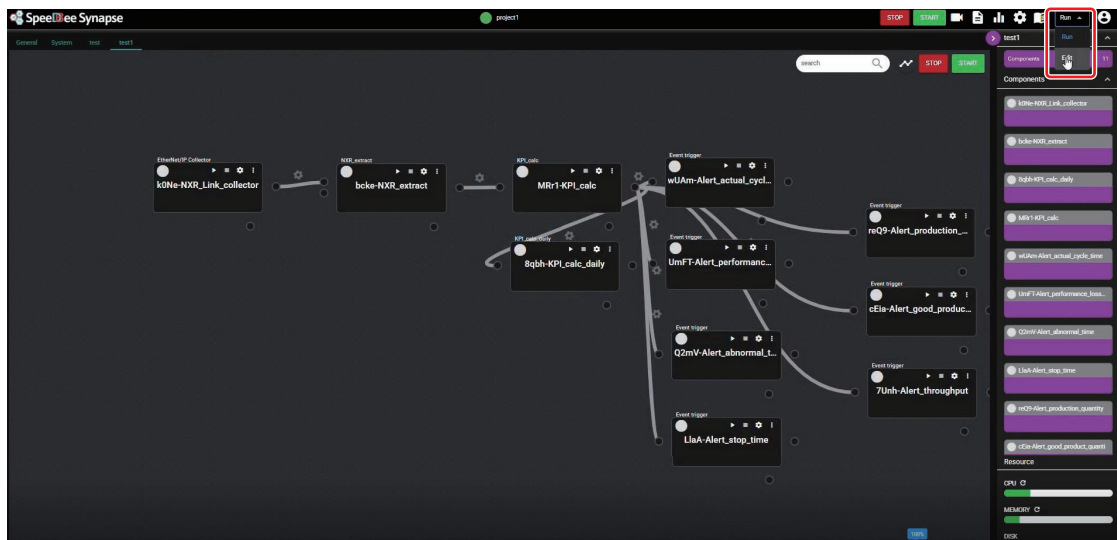

4 From the tab on the left, select **EtherNet/IP Collector** and place it.

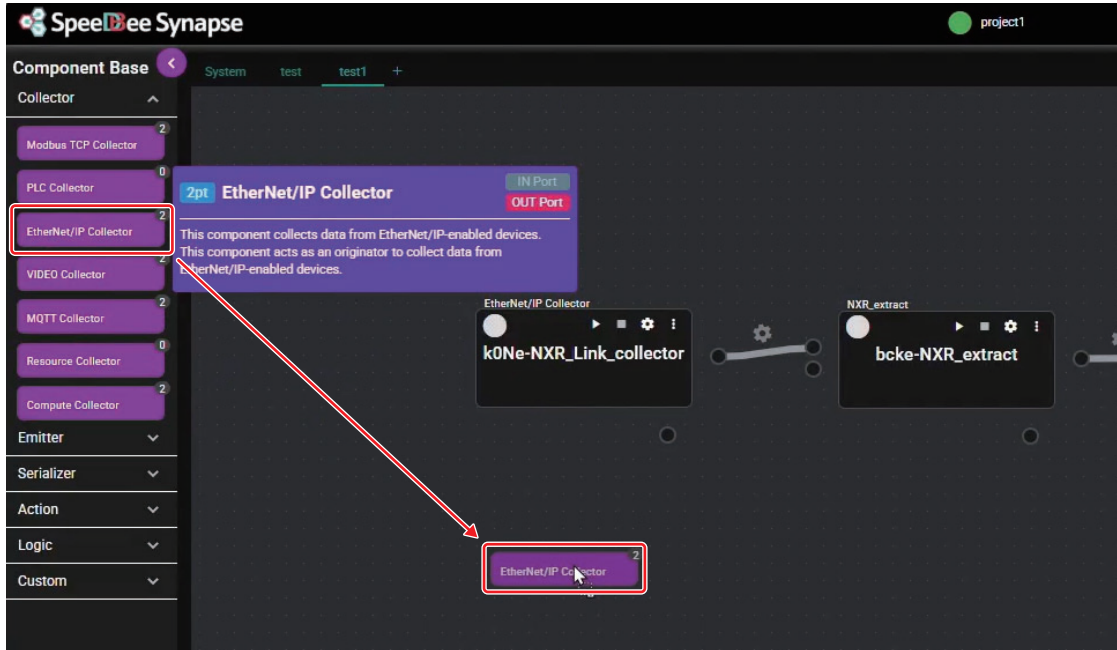

5 Configure the placed **EtherNet/IP Collector**.

Item	Description
Name	The name of the component. Example: Error_signal_collector
Host	The IP address of the host. Set the IP address of the NX102-9000. Example: 192.168.250.1
Get Interval	The data acquisition interval. Set to 100 ms.

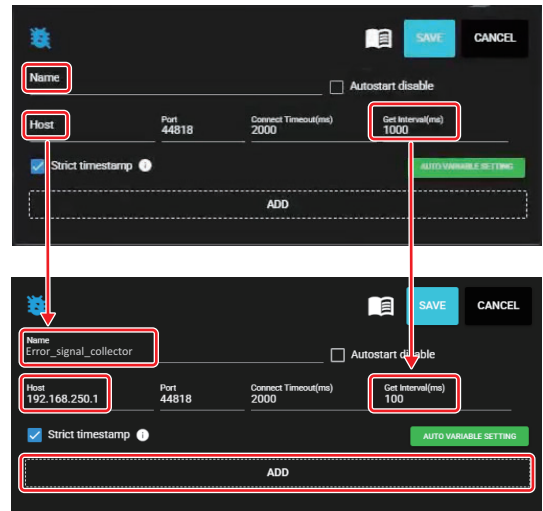

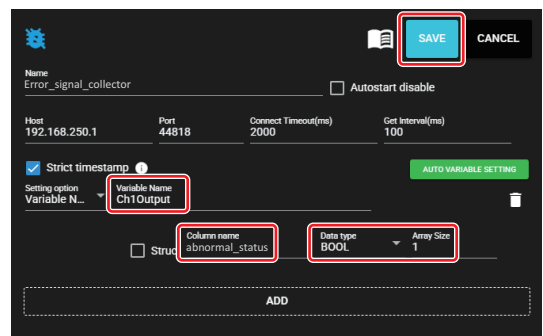

6 Click the **ADD** Button to continue configuration. After configuration, click the **SAVE** Button.

Item	Description
Variable Name	Set the NX-OD variable. Example: Ch1Output
Column Name	The name of the acquisition column. Example: abnormal_status
Data Type/ Array Size	Set the data type of the variable Ch1Output. Example: BOOL, 1

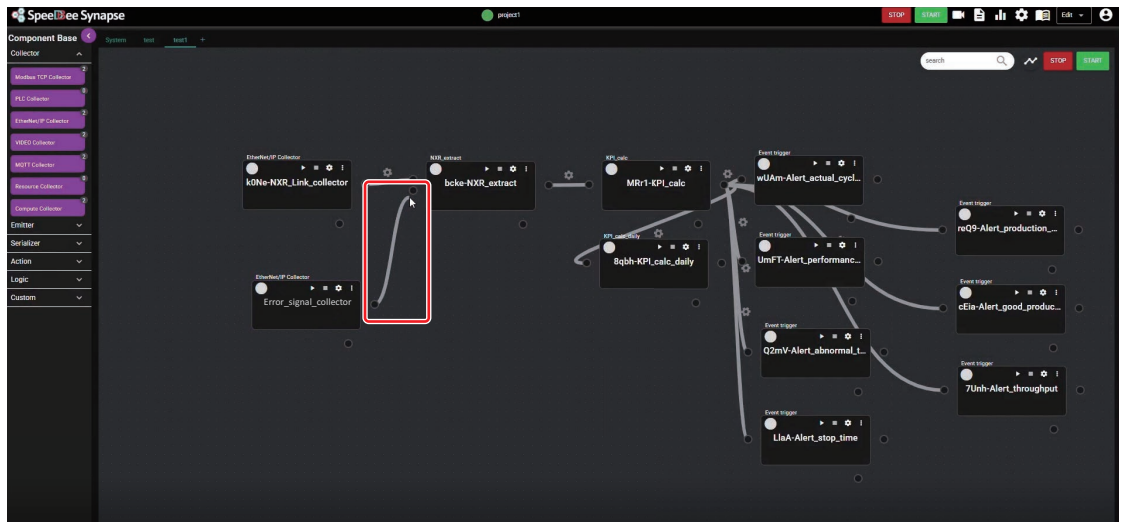

- 7 Connect the output port ● on the right side of the created component to the input port ● on the left side of the *NXR extract* Component.



- 8 Click the  (Launch) Button on the *NXR extract* Component.

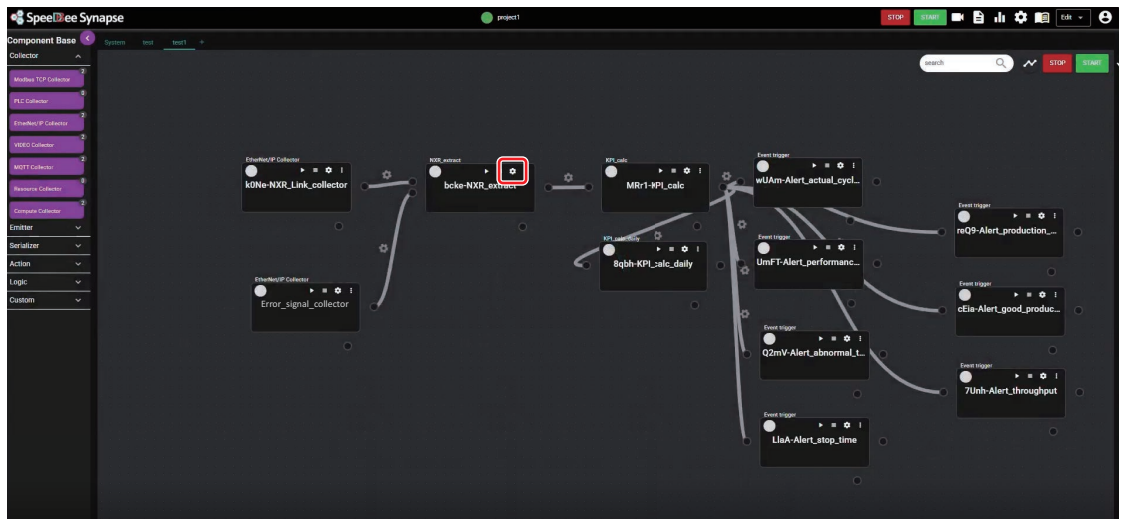

- 9 Set **Abnormal Measurement Sensor** to None.

- 10 Click the **SAVE** Button.

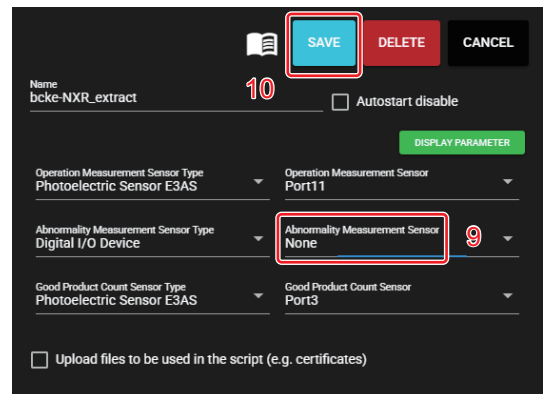

11 Click the **START** Button.

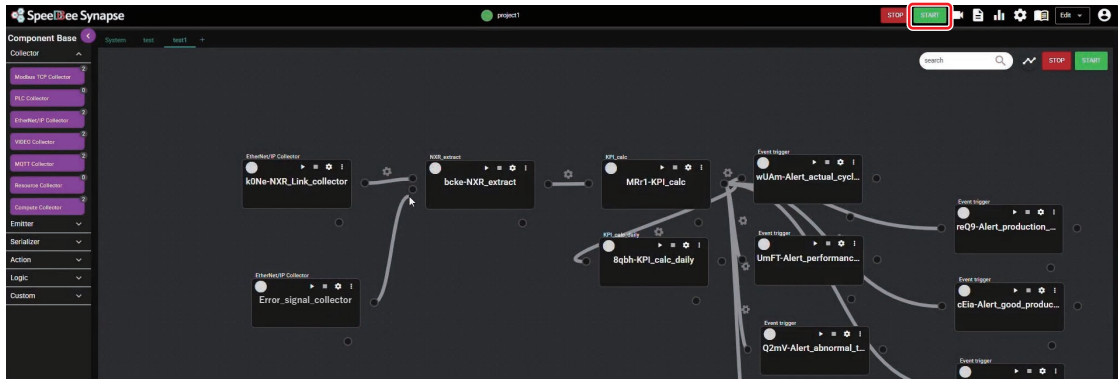

12 Click the *System Tab* at the top left (for Error Manager configuration).

The *System Panel* will appear.

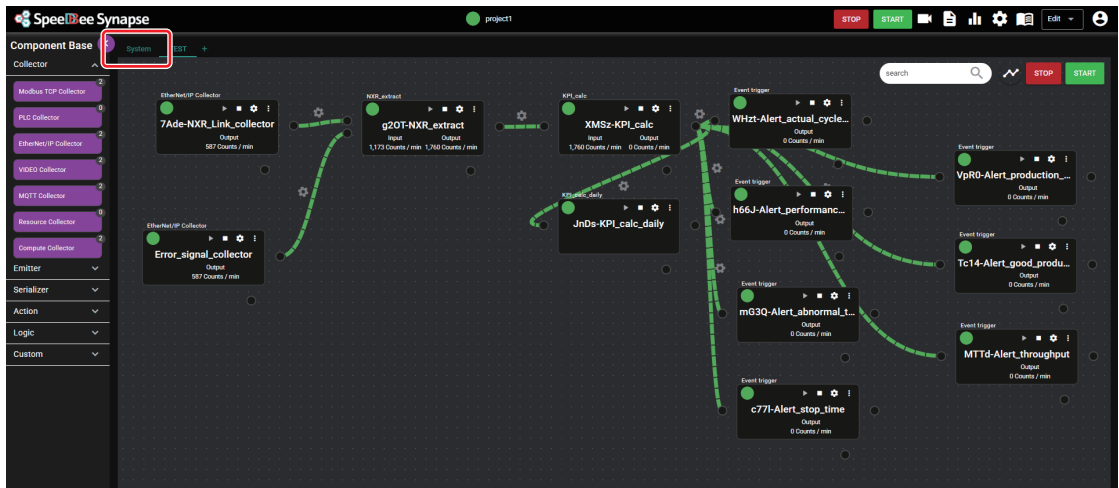

13 Click the **(Launch)** Button on the *Error Manager Component*.

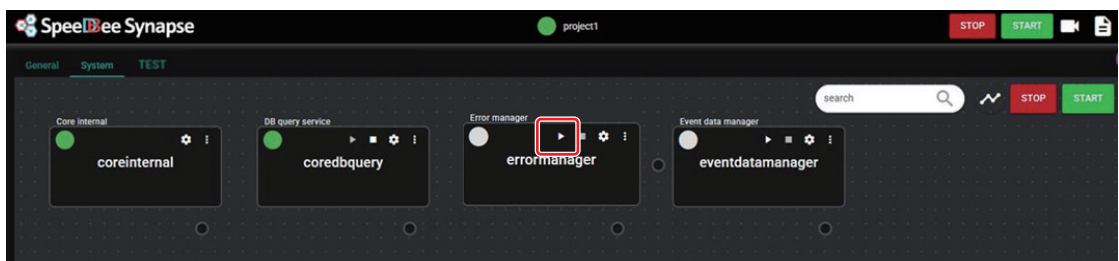

The Error Manager will start.

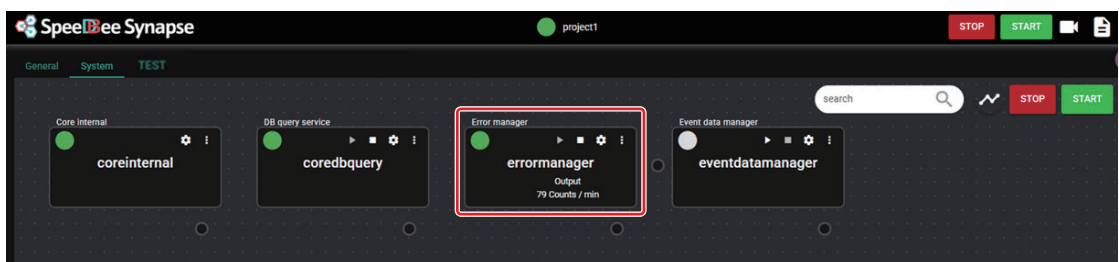

Note: Error Manager is required for Grafana to retrieve data from Synapse.

Dashboard List Screen - Launching Grafana

- 1 Click the graph icon in the upper-right corner of the *Synapse Screen*.

The *Grafana Screen* will appear.

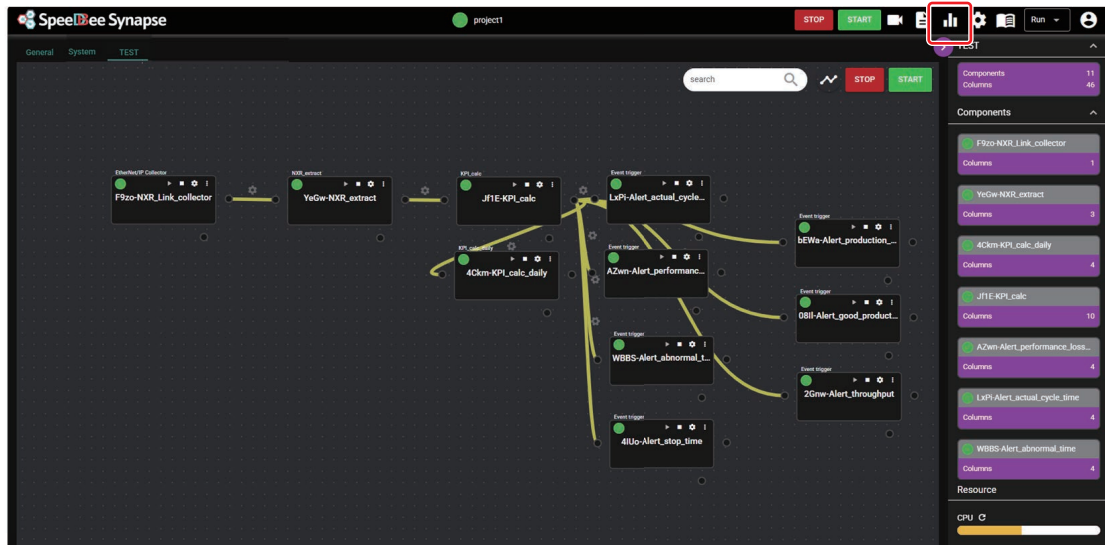

- 2 Click **Dashboards**.

The screen switches.

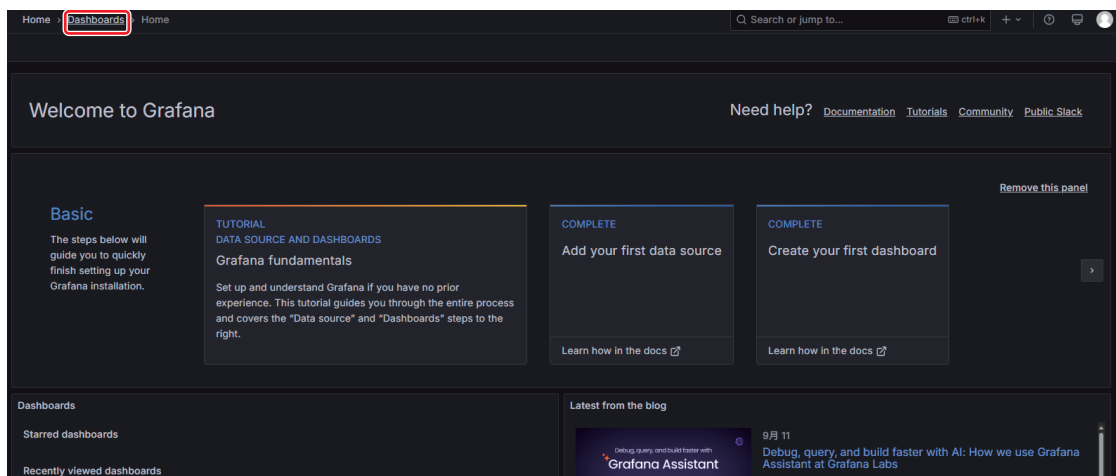

- 3 Click any dashboard name that has been added.

Example: TEST

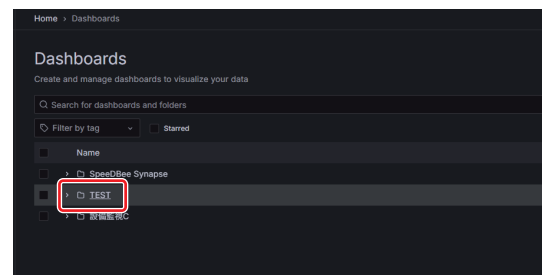

4 Click **Production Result Dashboard**.

The screen switches.

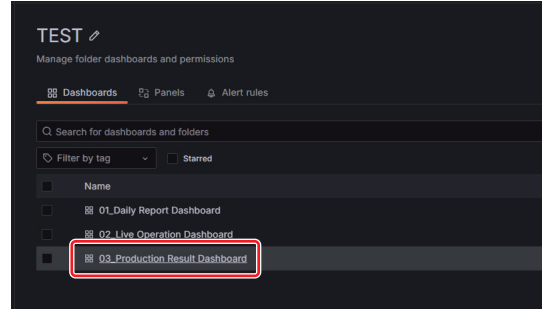

5 The KPI is displayed as a graph.

To change the data range, use the dropdown menu labeled **Last 1 hour JST**.

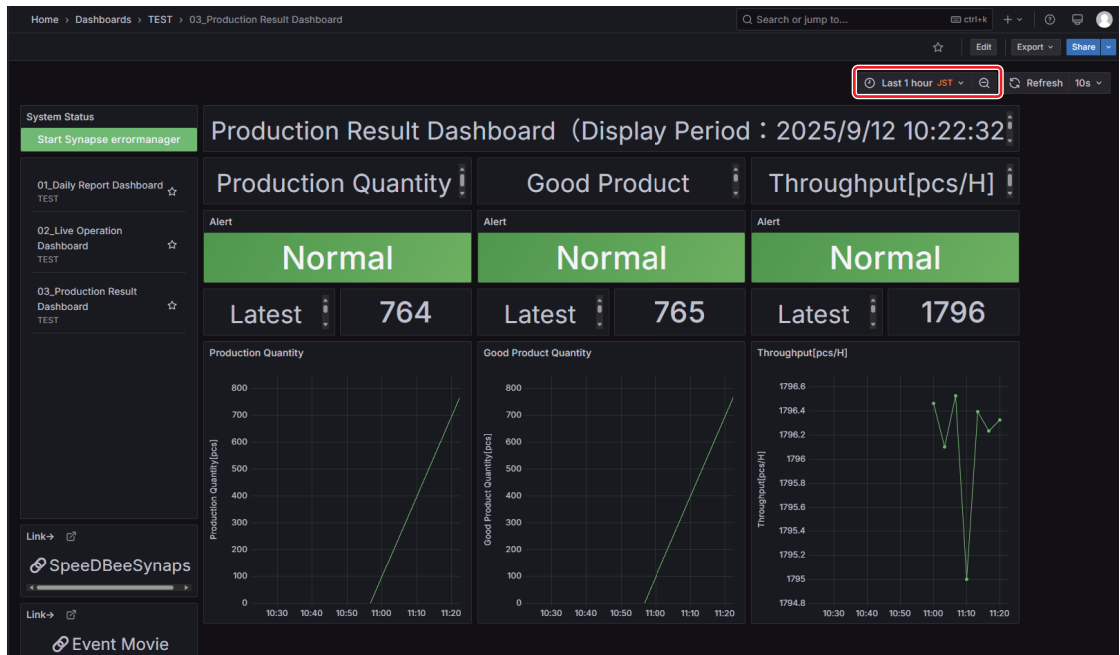

In this example, **Last 5 minutes** is selected.

Note: The vertical axis (values) of the graph automatically adjusts its scale based on the range of acquired data.

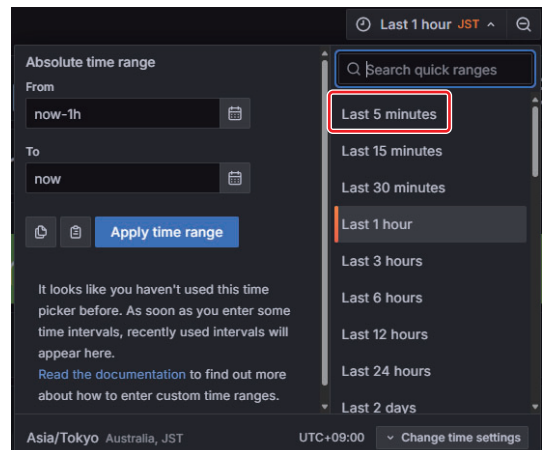

- 6** To adjust the data refresh frequency, click **Refresh** Button at the top right. Select the desired interval from the dropdown menu.

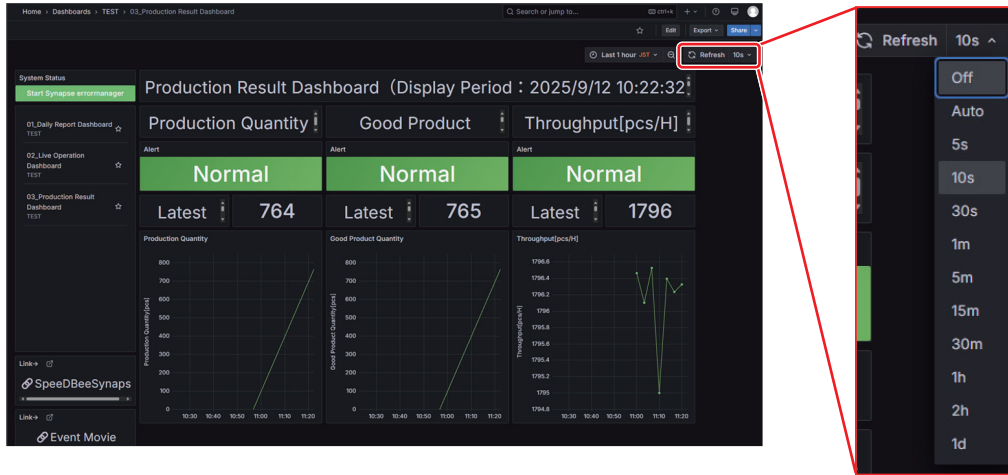

2-3 Threshold Configuration for Equipment Monitoring Package

Once the setup described in *section 2-2 Starting the Equipment Monitoring Package* is completed, KPI data becomes available.

To operate monitoring effectively, thresholds must be configured for each KPI to determine and visualize “normal” and “abnormal” conditions.

This section outlines the procedure for configuring thresholds.

Configured thresholds are stored within Synapse and Grafana on the Data Flow Controller.

Based on these thresholds, the Data Flow Controller evaluates the KPI data to determine whether the status is normal or abnormal.

Configuration Procedure

- 1 On the *Dashboard List Screen*, click the **Detail** Button for the displayed the Dashboard name field.

The *KPI Panels Screen* will appear.

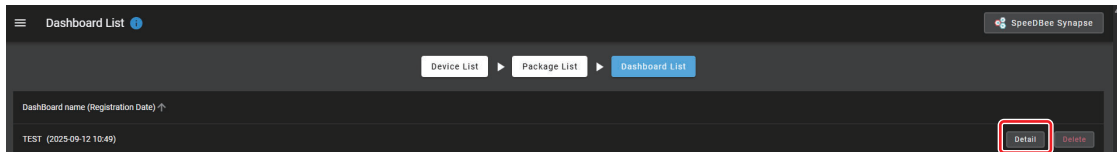

- 2 Click the **Threshold / Alert Settings** Button for the KPI.

In this example, the Speed [mm/s] is configured.

Continue with the following steps to set thresholds for each KPI.

The *Set Threshold and Alerts Screen* will appear.

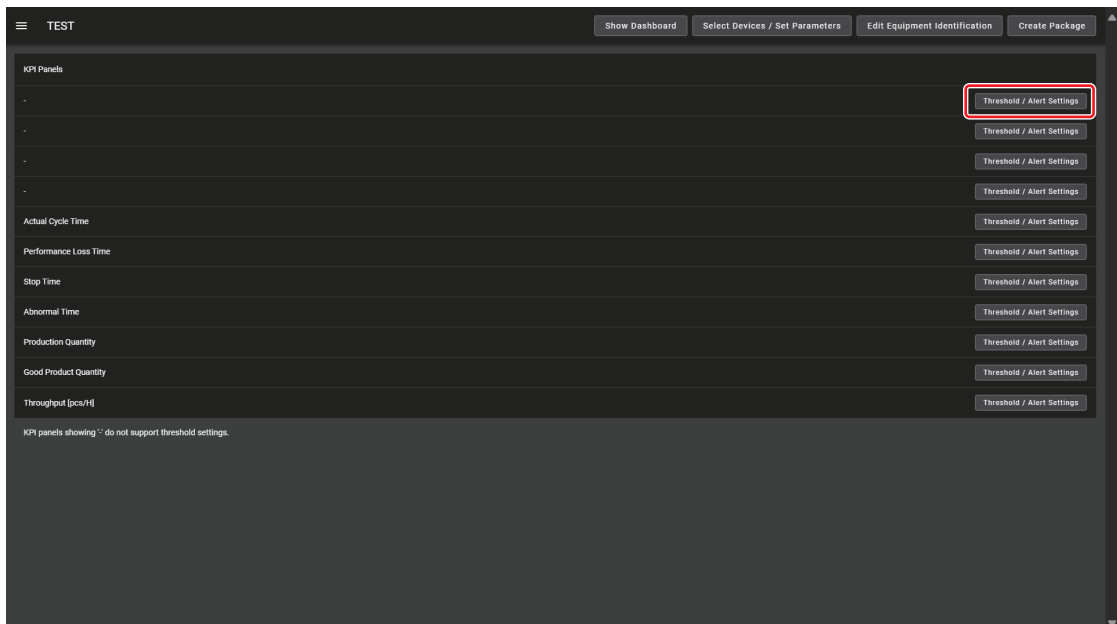

- 3** Configure the information on the *Set Threshold and Alerts Screen*.
After setting the calculation period, the **Calculate** Button becomes active. Click it to proceed.

Configuration Item	Selected Item
Type	Standard Deviation, Absolute Value, Range Specification, Maximum Value, Average Ratio, Standard Deviation, and Not Set
Calculation Period	Specify the data range. Time can be set down to seconds.
Alert Condition	Alert conditions are displayed. Values can be adjusted.
Calculation Result	The calculated threshold value is displayed.

Example Setting: *Standard Deviation*

- 4** Click the **Apply** Button.



Precautions for Correct Use

■ Threshold/Alert Configuration: Calculation Period Settings

A custom calculation period can be configured.

By default, with a memory retention period of 600 seconds, the data used for threshold calculations is limited to the most recent 10 minutes.

If the configured calculation period is shorter than 10 minutes, thresholds will be calculated based on that shorter duration.

To set a longer calculation period, the data retention period must be modified.

Refer to *section 2-6 Setting the Data Range Handled by the Dashboard* in the *DX Series Dashboard Generator User's Manual* for instructions.

■ Data Storage Location

When the Data Flow Controller is powered off, data is cleared under the default configuration (USB port disabled).

To retain previously collected data, enable the USB port and use a USB memory device.

Refer to *section 2-5 Changing the Data Storage Location* in the *DX Series Dashboard Generator User's Manual* for configuration steps.

5 Click the **Show Dashboard** Button.

The *Grafana* Screen will appear.

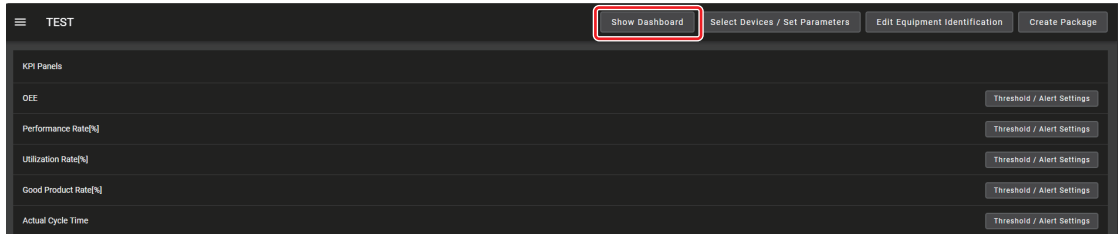

6 Hover over the **Menu** Button and click **Edit**.

Verify that the threshold has been applied. (The example shown below is from the Condition Monitoring Package.)

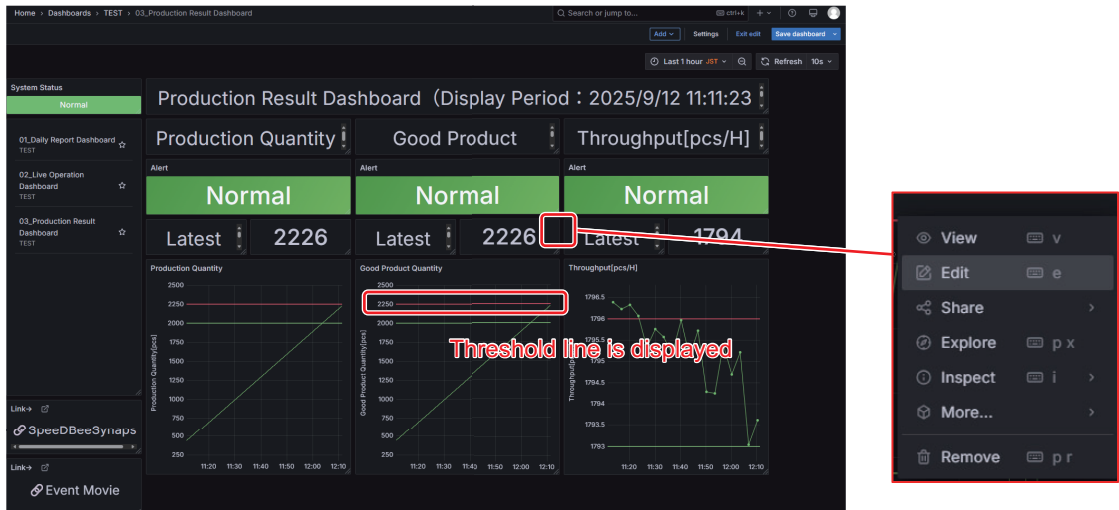

7 Confirm that the threshold value is displayed in the right-hand section.

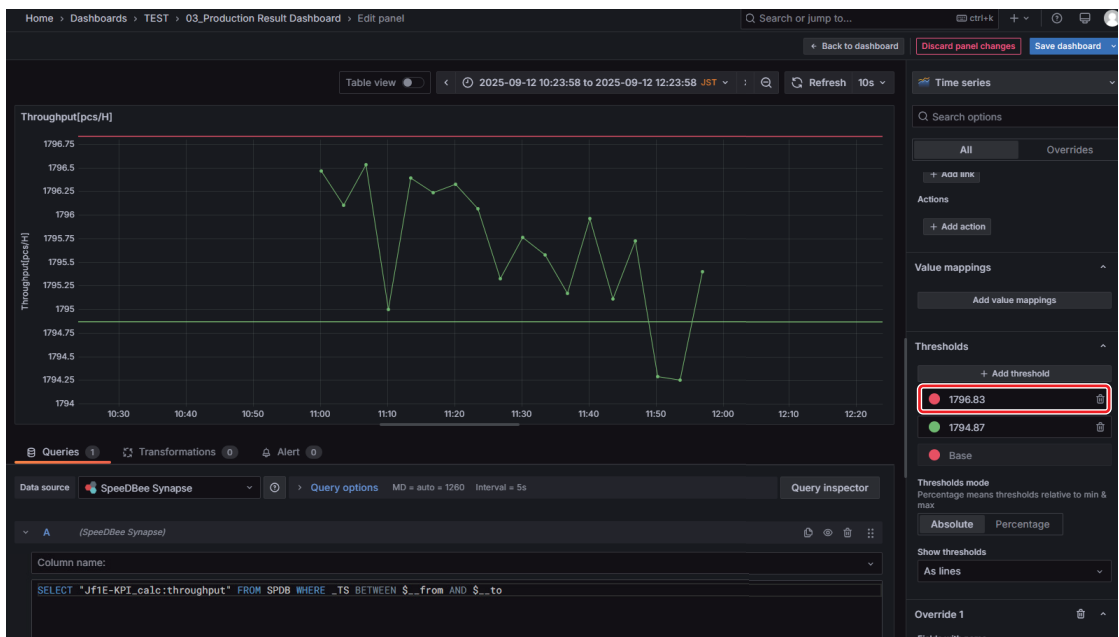

2-4 Method for Outputting KPIs of the Equipment Monitoring Package

This section describes how to output KPI data (Overall Equipment Effectiveness (OEE), performance availability, time availability, and yield rate) to a file.

1 Configuration of KPI Calculation Component

The KPI calc daily component aggregates operation data on a daily basis. The KPI calc daily component calculates KPIs (Overall Equipment Effectiveness (OEE), performance availability, time availability, and yield rate). The KPI calc daily component has two output ports. The upper output port is used for Grafana display. The lower output port is used to output data to subsequent components.

2 File Output Method

Connect a CSV Serializer and a File Emitter to the lower output port of the KPI_calc_daily component.

3 CSV Serializer Settings

Set Switching criterion to [Window]. Set Number of switching windows to [1].

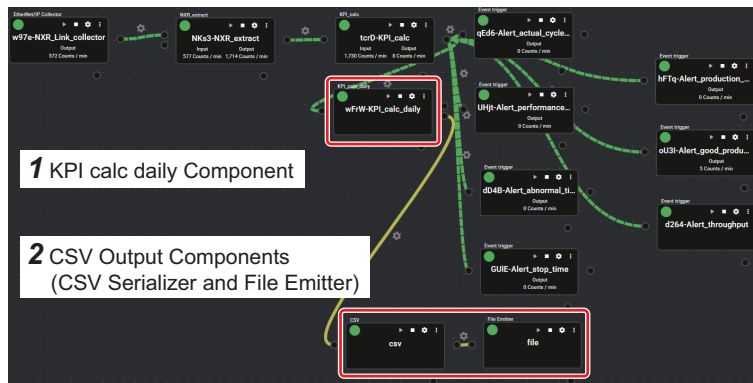

3 CSV Serializer Settings Screen

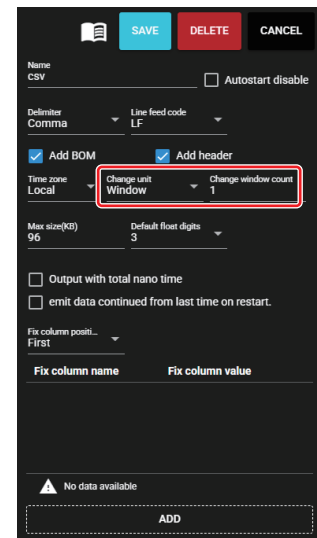

4 Output Data Specifications

The output data specifications are as follows.

The KPI data corresponds to aggregation_date. The timestamp (data output time) does not correspond to the KPI data.

timestamp	Data output time
aggregation_date	KPI calculation time
oee	Overall equipment effectiveness [%]
performance_rate	Performance availability [%]
utilization_rate	Time availability [%]
good_product_rate	Yield rate [%]

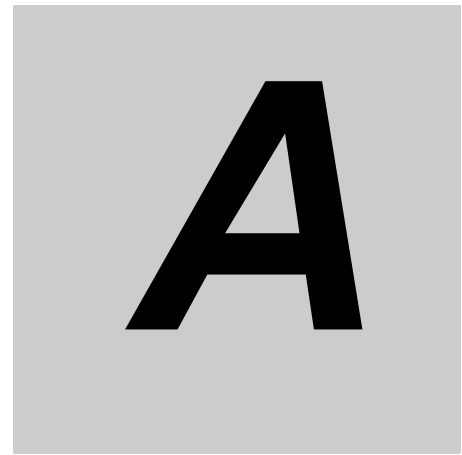

Appendices

A-1 KPI Calculation Method	A-2
----------------------------------	-----

A

A-1 KPI Calculation Method

This section explains the method for calculating KPIs.

No	KPI	Description
(1)	OEE (Overall Equipment Effectiveness) [%]	Utilization Rate × Performance Rate × Good Product Rate Calculated once per day at 0:00.
(2)	Utilization Rate [%]	$[(\text{Load Time} - \text{Stop Time}) \div \text{Load Time}] \times 100\%$ Load Time = 24 hours - Planned Downtime This is the ratio of time the equipment was actually operating during the day. The time excluding "Planned Downtime" from 24 hours is defined as the "Load Time" when equipment is operating. Calculated once per day at 0:00.
(3)	Performance Rate [%]	$\text{Actual Production Quantity (Daily Cycle Count)} \times \text{Standard Cycle Time} \div \Sigma(\text{Actual Cycle Time}) \times 100\%$ This is the ratio of the actual cycle time taken for production compared to the standard set cycle time. Calculated once per day at 0:00.
(4)	Good Product Rate [%]	$\text{Good Product Quantity} \div \text{Production Quantity} \times 100\%$ This is the ratio of good product quantity to production quantity in daily production. Calculated once per day at 0:00.
(5)	Actual Cycle Time [s]	The time from when the Operation Status sensor rises from OFF to ON until the next rise. Calculated each time the Operation Status turns ON.
(6)	Performance Loss Time [s]	The difference between the Actual Cycle Time taken for actual production and the Standard Cycle Time. Calculated each time the Operation Status turns ON.
(7)	Abnormal Time [s]	The time when the Abnormal Status is ON. Calculated each time the Abnormal Status turns OFF after being ON.
(8)	Stop Time [s]	The time when the equipment was stopped. Equipment is determined to be stopped when the Actual Cycle Time exceeds the set "Stop Detection Threshold L" × "Standard Cycle Time". Calculated when the Operation Status turns ON.
(9)	Production Quantity [pcs]	Counts the number of times the Operation Status turns ON as Production Quantity. Production Quantity is reset after calculating KPI once per day.
(10)	Good Product Quantity [pcs]	Counts the number of times the Good Product Count sensor turns ON as Good Product Quantity. Good Product Quantity is reset after calculating KPI once per day.
(11)	Throughput [pcs/h]	$N \div \text{Time taken to produce } N \text{ units} = N \div \text{Sum of } N \text{ Actual Cycle Times}$ This is the production quantity per hour. Calculated when Production Quantity reaches N units based on the setting "Throughput Calc Unit N".
(12)	Planned Downtime [min]	Set the time when equipment is stopped such as lunch breaks or nighttime as "Planned Downtime".
(13)	UTC Offset	Specifies the time to calculate KPI displayed on the Daily Report Dashboard. For Japan, since it is UTC+9 hours, setting "9" will execute KPI calculation at 0:00. UTC: Universal Time Coordinated
(14)	Standard Cycle Time [s]	Set the standard cycle time when operating the monitored equipment. Various KPIs are calculated based on this Standard Cycle Time.

No	KPI	Description
(15)	Stop Detection Threshold L	Set the time to determine if equipment has stopped. Set as a multiple of the Standard Cycle Time. For example, if Standard Cycle Time is 1 second and Stop Detection Threshold L is 4, equipment is determined to have stopped when Actual Cycle Time exceeds 1 second × 4 = 4 seconds. Stop time is recorded when Operation Status turns ON afterwards.
(16)	Throughput Calc Unit N [pcs]	Set the unit for calculating throughput by quantity. When N=100, throughput is calculated when 100 units are produced, i.e., when Actual Cycle Time has been counted 100 times.

No	KPI
(1)	OEE (Overall Equipment Effectiveness) [%]
(2)	Utilization Rate [%]
(3)	Performance Rate [%]
(4)	Good Product Rate [%]
(5)	Actual Cycle Time [s]
(6)	Performance Loss Time [s]
(7)	Abnormal Time [s]
(8)	Stop Time [s]
(9)	Production Quantity [pcs]
(10)	Good Product Quantity [pcs]
(11)	Throughput [pcs/h]

No	KPI
(12)	Planned Downtime [min]
(13)	UTC Offset
(14)	Standard Cycle Time [s]
(15)	Stop Detection Threshold L
(16)	Throughput Calc Unit N [pcs]

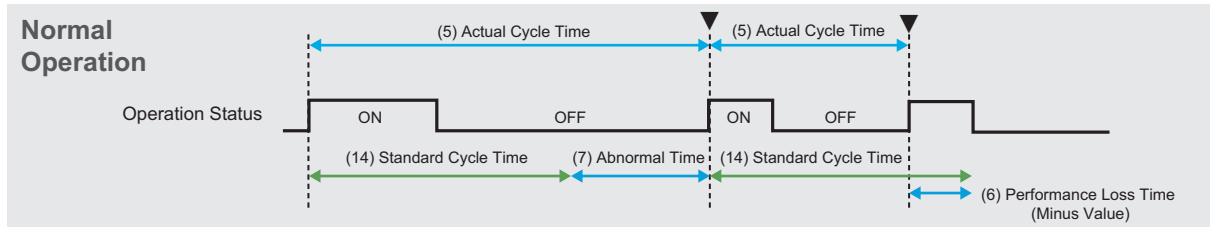

(7) Performance Loss Time is calculated as follows for each ▼ cycle:
 $(5) \text{ Actual Cycle Time} - (14) \text{ Standard Cycle Time (set value)}$

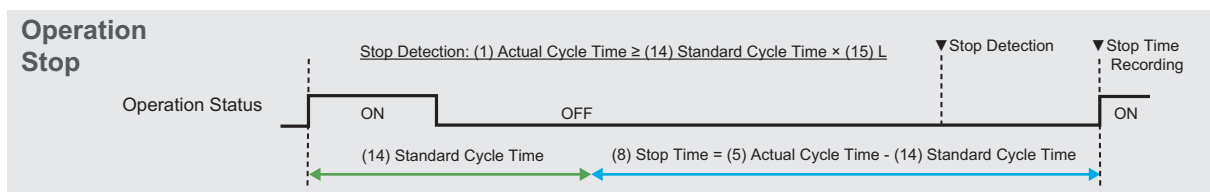

(8) Stop time is calculated using the following formula, after which stop detection is performed.
 [Time Calculation Method] $(1) \text{ Actual Cycle Time} - (14) \text{ Standard Cycle Time}$
 [Stop Detection Method] $(1) \text{ Actual Cycle Time} \geq (14) \text{ Standard Cycle Time} \times (15) \text{ Stop Detection Threshold L}$

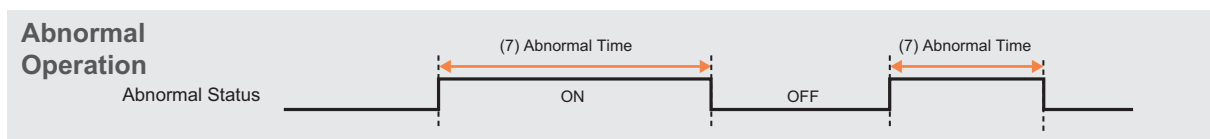

(7) Abnormal Time is the time when Abnormal Status is ON.

No	KPI
(1)	OEE (Overall Equipment Effectiveness) [%]
(2)	Utilization Rate [%]
(3)	Performance Rate [%]
(4)	Good Product Rate [%]
(5)	Actual Cycle Time [s]
(6)	Performance Loss Time [s]
(7)	Abnormal Time [s]
(8)	Stop Time [s]
(9)	Production Quantity [pcs]
(10)	Good Product Quantity [pcs]
(11)	Throughput [pcs/h]

No	KPI
(12)	Planned Downtime [min]
(13)	UTC Offset
(14)	Standard Cycle Time [s]
(15)	Stop Detection Threshold L
(16)	Throughput Calc Unit N [pcs]

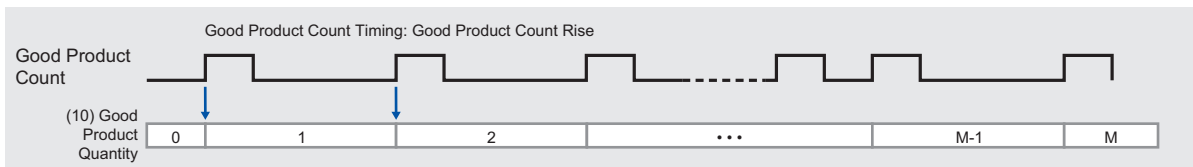
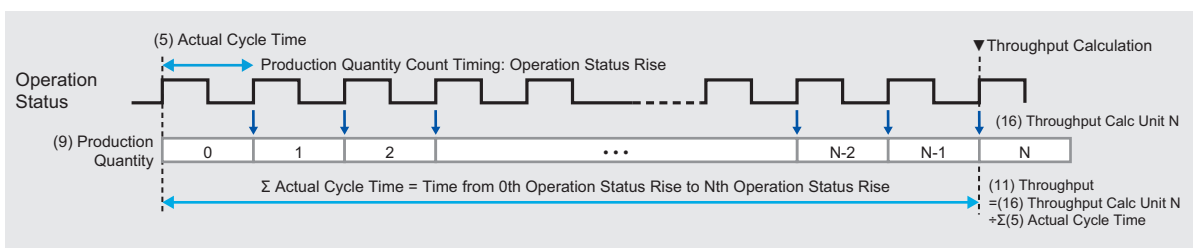

No	KPI
(1)	OEE (Overall Equipment Effectiveness) [%]
(2)	Utilization Rate [%]
(3)	Performance Rate [%]
(4)	Good Product Rate [%]
(5)	Actual Cycle Time [s]
(6)	Performance Loss Time [s]
(7)	Abnormal Time [s]
(8)	Stop Time [s]
(9)	Production Quantity [pcs]
(10)	Good Product Quantity [pcs]
(11)	Throughput [pcs/h]

No	KPI
(12)	Planned Downtime [min]
(13)	UTC Offset
(14)	Standard Cycle Time [s]
(15)	Stop Detection Threshold L
(16)	Throughput Calc Unit N [pcs]

(2) Utilization Rate [%] = $[(\text{Load Time} - \sum(8) \text{ Stop Time}) \div \text{Load Time}] \times 100\%$
 Load Time = 24 hours - (12) Planned Downtime
 Calculated once per day at 0:00

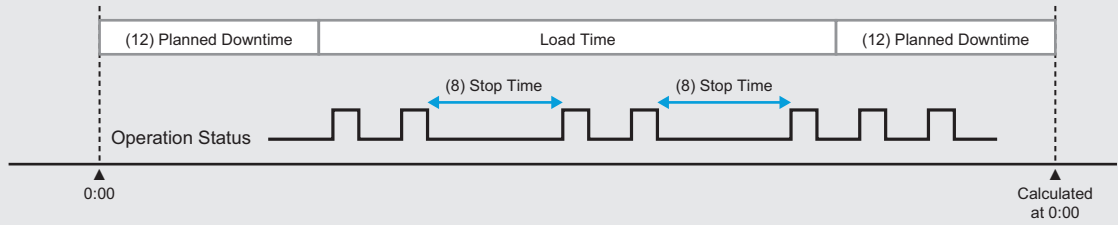

(3) Performance Rate [%] = $\text{Daily (9) Production Quantity} \times (14) \text{ Standard Cycle Time} \div \sum(5) \text{ Actual Cycle Time} \times 100\%$
 Calculated once per day at 0:00

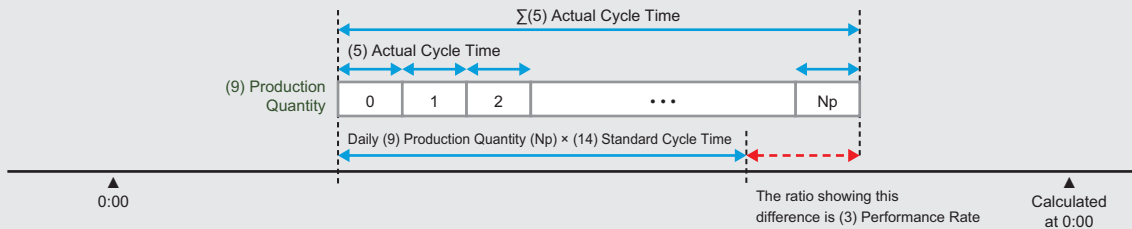

No	KPI
(1)	OEE (Overall Equipment Effectiveness) [%]
(2)	Utilization Rate [%]
(3)	Performance Rate [%]
(4)	Good Product Rate [%]
(5)	Actual Cycle Time [s]
(6)	Performance Loss Time [s]
(7)	Abnormal Time [s]
(8)	Stop Time [s]
(9)	Production Quantity [pcs]
(10)	Good Product Quantity [pcs]
(11)	Throughput [pcs/h]

No	KPI
(12)	Planned Downtime [min]
(13)	UTC Offset
(14)	Standard Cycle Time [s]
(15)	Stop Detection Threshold L
(16)	Throughput Calc Unit N [pcs]

(4) Good Product Rate = ((10) Good Product Quantity ÷ (9) Production Quantity) × 100
 Calculated once per day at 0:00
 Reset to 0 after calculation

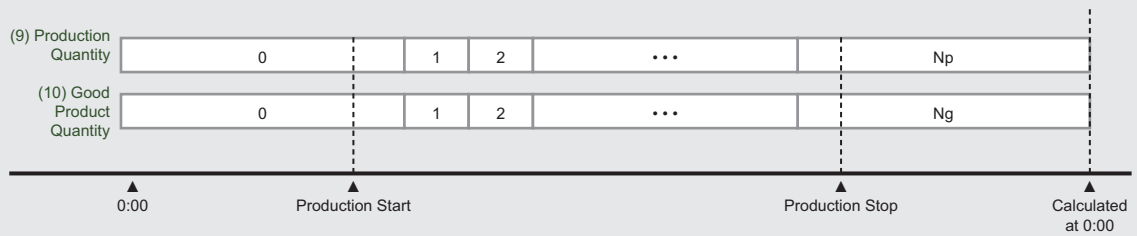

OMRON Corporation Industrial Automation Company

Kyoto, JAPAN

Contact : www.ia.omron.com

 Contact for inquiries for this product (only for DX-series)

DataPF-contactdesk-OC@omron.com

Operation Hours: 9:00 to 17:00 (except Saturdays, Sundays, and Dec. 31 to Jan. 3), JST



Tutorial Video

<https://www.fa.omron.co.jp/dx1/video-manual/en/>



Authorized Distributor:

©OMRON Corporation 2025-2026 All Rights Reserved.
In the interest of product improvement,
specifications are subject to change without notice.

Cat. No. N701-E1-03 0526