

## SmartVision MX

### User's Guide



## Copyright Notice

---

The information contained herein is the property of Omron Adept Technologies, Inc., and shall not be reproduced in whole or in part without prior written approval of Omron Adept Technologies, Inc. The information herein is subject to change without notice and should not be construed as a commitment by Omron Adept Technologies, Inc. The documentation is periodically reviewed and revised.

Omron Adept Technologies, Inc., assumes no responsibility for any errors or omissions in the documentation. Critical evaluation of the documentation by the user is welcomed. Your comments assist us in preparation of future documentation. Please submit your comments to: [techpubs@adept.com](mailto:techpubs@adept.com).

Copyright © 2014, 2017, 2019 by Omron Adept Technologies, Inc. All rights reserved.

Any trademarks from other companies used in this publication  
are the property of those respective companies.

Created in the United States of America

# Table of Contents

---

<b>Chapter 1: Introduction</b> .....	<b>7</b>
1.1 Product Description .....	7
Features .....	7
What Comes with a SmartVision MX? .....	8
What Doesn't Come with a SmartVision MX? .....	10
1.2 How Can I Get Help? .....	10
Related Manuals .....	10
<b>Chapter 2: Safety</b> .....	<b>11</b>
2.1 Dangers, Warnings, and Cautions .....	11
Alert Icons .....	11
Special Information .....	12
2.2 What to Do in an Emergency / Abnormal Situation .....	12
Stopping the Robot .....	12
Fire Response .....	12
2.3 Safety Precautions .....	12
2.4 Additional Safety Information .....	13
Manufacturer's Declarations .....	13
Robot Safety Guide .....	13
2.5 Disposal .....	13
<b>Chapter 3: Installation</b> .....	<b>15</b>
3.1 Inspecting .....	15
3.2 Transport and Storage .....	15
3.3 Mounting the SmartVision MX .....	15
Vertical Mounting .....	16
Desk-top Mounting .....	16
Stack Mounting .....	16
3.4 Connecting Power .....	18
External Power Supply .....	18
Recommended Power Supplies .....	19
Recommended UPS Units .....	19
Installing 24 VDC Connector .....	19
Connecting to a SmartController .....	20
3.5 Connecting Display, Keyboard, and Mouse .....	21

<b>Chapter 4: Connectors and Indicators</b> .....	<b>23</b>
Camera Side .....	23
Power/IO Side .....	24
4.1 Ethernet Ports .....	25
4.2 USB Ports .....	25
4.3 DVI- Ports .....	25
4.4 Audio and Serial Ports .....	25
<b>Chapter 5: Operation</b> .....	<b>27</b>
5.1 Operating Environment .....	27
5.2 Turning Power ON and OFF .....	27
5.3 Checking the Licenses on the Dongle .....	27
<b>Chapter 6: Technical Specifications</b> .....	<b>29</b>
6.1 Processor Specifications .....	29
6.2 Environmental Specifications .....	29
6.3 Power Requirements .....	29
6.4 Dimensions .....	30
6.5 Connections .....	31
6.6 Camera Specifications .....	32
<b>Chapter 7: Options</b> .....	<b>33</b>
7.1 License Options .....	33
Software License Details .....	33
7.2 Mounting Options .....	33
Mounting Kits .....	33

## Revision History

Revision code	Date	Revised Content
01	May, 2016	Original release
02	March, 2017	<ul style="list-style-type: none"> <li>• Added recommended Omron UPS units.</li> <li>• Changed to OAT.css.</li> <li>• Replaced dimension drawing in technical specifications.</li> <li>• Expanded no-internet caution.</li> <li>• Recommended vertical mounting.</li> <li>• Corrected power input and consumption.</li> <li>• Updated graphics for OAT logo and for better clarity.</li> </ul>
03	March, 2019	<ul style="list-style-type: none"> <li>• Added WEEE disposal information.</li> <li>• Removed reference to <a href="http://www.adept.com">www.adept.com</a>.</li> <li>• Updated copyright for 2019.</li> <li>• Added mounting bracket part number in Chapter 3: Installation.</li> <li>• Updated illustrations with call-outs for translation compatibility and other minor improvements.</li> <li>• Updated Chapter 2: Safety with new format and information.</li> <li>• Replaced discontinued S8JX-G power supply with replacement S8FS-G series.</li> <li>• Added missing captions to tables.</li> <li>• Added bracket number, detail and adjusted figures in Chapter 3: Installation.</li> <li>• Added mounting kit information</li> <li>• Modified software license details to Chapter 7: Options .</li> <li>• Updates to indicate Digital I/O is not supported.</li> <li>• Updated USB license dongle details.</li> <li>• Added camera specifications table to Chapter 6: Technical Specifications.</li> </ul>



# Chapter 1: Introduction

## 1.1 Product Description

The SmartVision MX is a Windows® 7 Embedded industrial PC designed to run ACE software. It is compatible with the SmartController line of products, or can be used with our robots that don't use a SmartController.

For inspection applications, the SmartVision MX industrial PC is designed to be a “plug-and-play” vision system. Using a USB or GigE camera, along with ACE's PC-based vision software, the unit is a complete industrial vision solution.

When used with a SmartController, the SmartVision MX provides expanded vision processing power for vision-guided robotics or inspection.



Figure 1-1. The SmartVision MX Industrial PC

### Features

The SmartVision MX provides the following features:

- Compatibility with the SmartController line of products
- Intel PC platform, with Core i7 processor
- Windows 7 Embedded OS
- Ports for both Gigabit and USB 3.0 cameras

Four Gigabit ports provide Power over Ethernet.

- Standard Gigabit LAN
- Standard RS-232 interface
- Both DVI-D and DVI-I ports
- USB ports can support a keyboard and mouse, for standalone operation
- DVI-D or DVI-I ports can support a monitor, for standalone operation

### What Comes with a SmartVision MX?

#### Hardware

The SmartVision MX includes:

- Intel® Core i7
- 8 GB DDR3 memory
- 64 GB mSATA SSD drive

The drive is partitioned into a C: drive and a D: drive. By default, the C: drive uses a file-based write filter, to protect the Windows operating system and ACE software. We recommend that you leave this write filter enabled for C: in normal use.

Because the OS and ACE software are on C:, you should be very cautious about using C: for any other purpose, particularly for other applications.

- Matching connector for VDC input power
- A USB license dongle, which enables licenses for one or more of the following:
  - ACE Sight software, 2 camera support (ACE 3.7+ license does not restrict number of cameras)
  - ACE PackXpert, 1 controller support (ACE 3.7+ license does not restrict number of controllers)
  - ACE PackXpert with ACE Sight software, 2 camera and 1 controller support (ACE 3.7+ license does not restrict number of controllers or cameras)
  - Any additional camera or controller licenses that you purchased
  - Other licenses can be purchased to increase the number of cameras and controllers supported (ACE 3.6 or earlier)



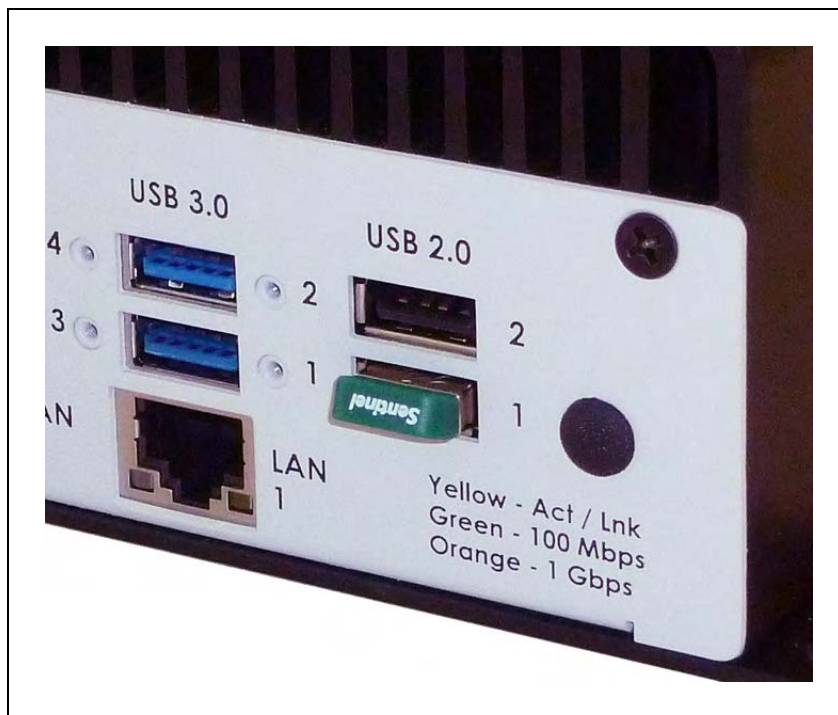

Figure 1-2. USB License Dongle in USB 2.0 Port 1

A SmartVision MX can support a total of eight cameras and four controllers.

### Software

The following software is pre-loaded on the hard drive:

- Windows® 7 Embedded
- ACE
- ACE Sight 3 (ACE-based vision software)
- Drivers for Basler ACE cameras (USB and GigE)

The SmartVision MX is designed to run ACE software. We do not support applications other than ACE.

### Options

For details on options, see Options on page 33.

- Extended licenses, enabled on the USB license dongle
- Stack-mounting brackets

### What Doesn't Come with a SmartVision MX?

- 24 VDC power supply to power the SmartVision MX industrial PC (see External Power Supply on page 18).
  - Cameras and camera cables
  - Keyboard, mouse, and monitor
- These should be user-supplied, so you can run the ACE and ACE Sight applications, and well as control shutting down the industrial PC.
- If power interruption is a concern, a UPS is recommended (see External Power Supply on page 18).

## 1.2 How Can I Get Help?

For details on getting assistance with your software or hardware, you can access the corporate website:

<http://www.ia.omron.com>

### Related Manuals

This manual covers the installation and use of a SmartVision MX. The following manuals provide information on safety, related products, advanced configurations and system specifications.

*Table 1-1. Related Manuals*

<b>Manual Title</b>	<b>Description</b>
<i>Robot Safety Guide</i>	Contains safety information for our robots.
<i>ACE User's Guide</i>	Instruction for the use of the ACE software.
<i>ACE Sight User's Guide</i>	Instruction for the use of the ACE Sight software.
<i>SmartController EX User's Guide</i>	Contains information on the installation and operation of the optional SmartController EX and sDIO products.

# Chapter 2: Safety

## 2.1 Dangers, Warnings, and Cautions

There are three levels of alert notation used in our manuals. In descending order of importance, they are:



**DANGER:** Identifies an imminently hazardous situation which, if not avoided, is likely to result in serious injury, and might result in fatality or severe property damage.



**WARNING:** Identifies a potentially hazardous situation which, if not avoided, will result in minor or moderate injury, and might result in serious injury, fatality, or significant property damage.





**CAUTION:** Identifies a potentially hazardous situation which, if not avoided, might result in minor injury, moderate injury, or property damage.

### Alert Icons

The icon that starts each alert can be used to indicate the type of hazard. These will be used with the appropriate signal word - Danger, Warning, or Caution - to indicate the severity of the hazard. The text following the signal word will specify what the risk is, and how to avoid it.

Table 2-1. Alert Icon Meaning

Icon	Meaning
	This is a generic alert icon. Any specifics on the risk will be in the text following the signal word.
	This identifies a hazardous electrical situation.

## Special Information

There are several types of notation used to call out special information.

**IMPORTANT:** Information to ensure safe use of the product.

**NOTE:** Information for more effective use of the product.

**Additional Information:** Offers helpful tips, recommendations, and best practices.

**Version Information:** Information on differences in specifications for different versions of hardware or software.

## 2.2 What to Do in an Emergency / Abnormal Situation

### Stopping the Robot

Press any E-Stop button (a red push-button on a yellow background) and then follow the internal procedures of your company or organization for an emergency situation.

### Fire Response

If a fire occurs, use CO<sub>2</sub> to extinguish the fire.

## 2.3 Safety Precautions



**WARNING: ELECTROCUTION RISK**

During maintenance, disconnect AC power from the robot, and install a lock-out tag-out to prevent anyone from reconnecting power.



**WARNING: PERSONAL INJURY OR PROPERTY DAMAGE RISK**

A robot can cause serious injury or death, or damage to itself and other equipment, if the safety precautions in this manual are not observed:

- All personnel who install, operate, teach, program, or maintain the system must read this guide, read the *Robot Safety Guide*, and complete a training course for their responsibilities in regard to the robot.



Figure 2-1. Read Manual and Impact Warning Labels

- All personnel who design the robot system must read this guide, read the *Robot Safety Guide*, and must comply with all local and national safety regulations for the location in which the robot is installed.
- The robot system must not be used for purposes other than described in the robot user's guide. Contact your local Omron support if you are not sure of the suitability for your application.
- The user is responsible for providing safety barriers around the robot to prevent anyone from accidentally coming into contact with the robot when it is in motion.
- Power to the robot and its power supply must be locked out and tagged out before any maintenance is performed.

## 2.4 Additional Safety Information

We provide other sources for more safety information:

### Manufacturer's Declarations

This lists the standards with which our robots and controllers comply. The Manufacturer's Declarations are in the Manufacturer's Declarations Guide.

### Robot Safety Guide

The Robot Safety Guide provides detailed information on safety for our robots. It also gives resources for more information on relevant standards. It ships with each robot.

## 2.5 Disposal



Dispose of in accordance with applicable regulations.

Customers can contribute to resource conservation and protecting the environment by the proper disposal of WEEE (Waste Electronics and Electrical Equipment). All electrical and electronic products should be disposed of separately from the municipal waste system via designated collection facilities. For information about disposal of your old equipment, Contact your local Omron support.



## Chapter 3: Installation

---

The SmartVision MX should be shipped and stored in the supplied packaging, which is designed to prevent damage from normal shock and vibration. You should protect the package from excessive shock and vibration. For environmental specifications, refer to Environmental Specifications on page 29.

### 3.1 Inspecting

Carefully inspect all packaging for evidence of damage during transit. If any damage is indicated, request that the carrier's agent be present at the time the package is opened.

Compare the actual items received (not just the packing slip) with your equipment purchase order, and verify that all items are present and that the shipment is correct. Inspect each item for external damage as it is unpacked. Contact your local Omron support immediately if any damage is evident. See "How Can I Get Help?" section on page 15.

Retain all containers and packaging materials. These items may be needed in the future to settle a damage claim.

Remove the SmartVision MX. Mount it near the robot.

### 3.2 Transport and Storage

The SmartVision MX must be shipped and stored in a temperature-controlled environment, within the range -25 to 60°C (-13 to 140°F). The recommended humidity range is 5 to 90%, non-condensing.

It must always be stored and shipped in a clean, dry area that is free from condensation.

### 3.3 Mounting the SmartVision MX

**NOTE:** The SmartVision MX is not intended for use in hazardous environments (explosive gas, water, dust, oil mist) or in the presence of ionizing or non-ionizing radiation.

The base of the industrial PC has four tabs with holes for screwing it to a flat surface. These are also used when mounting to a SmartController with the optional stack-mount brackets.

Regardless of the mounting method used, allow adequate space around the unit for air circulation.

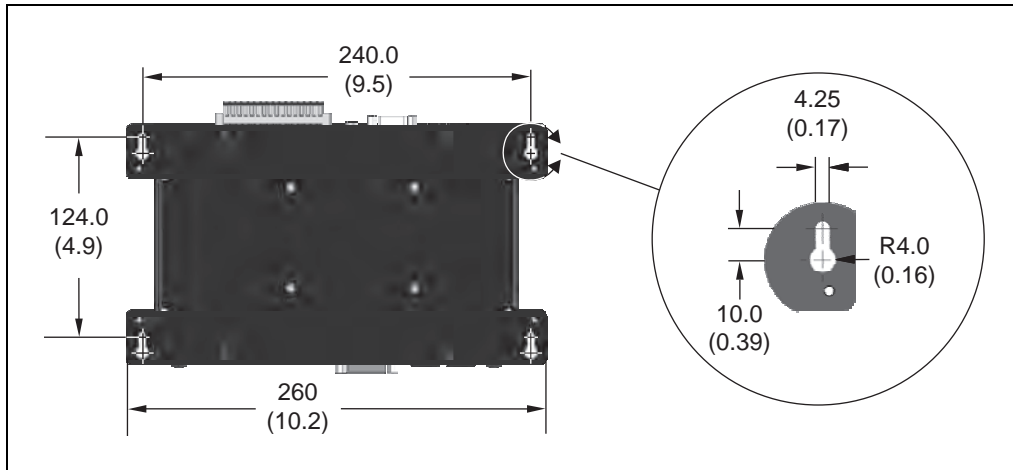

Figure 3-1. Dimensions for Mounting (Units in mm)

#### Vertical Mounting

Vertical mounting against a cabinet wall using the four bottom tabs is the recommended mounting method.

Use 6-32 UNC screws, or screws of similar specifications, for mounting the processor to a vertical surface. The screw length is determined by the surface being mounted to.

#### Desk-top Mounting

Use 6-32 UNC screws, or screws of similar specifications, for mounting the processor to a flat surface. The screw length is determined by the surface being mounted to.

#### Stack Mounting

The SmartVision MX industrial PC can be stack-mounted on top of a SmartController, if there is one in the system, using two mounting brackets (14393-000) available as an option with the industrial PC. Refer to Chapter 7: Options for more information.

Views of the bracket are shown in the following figure.



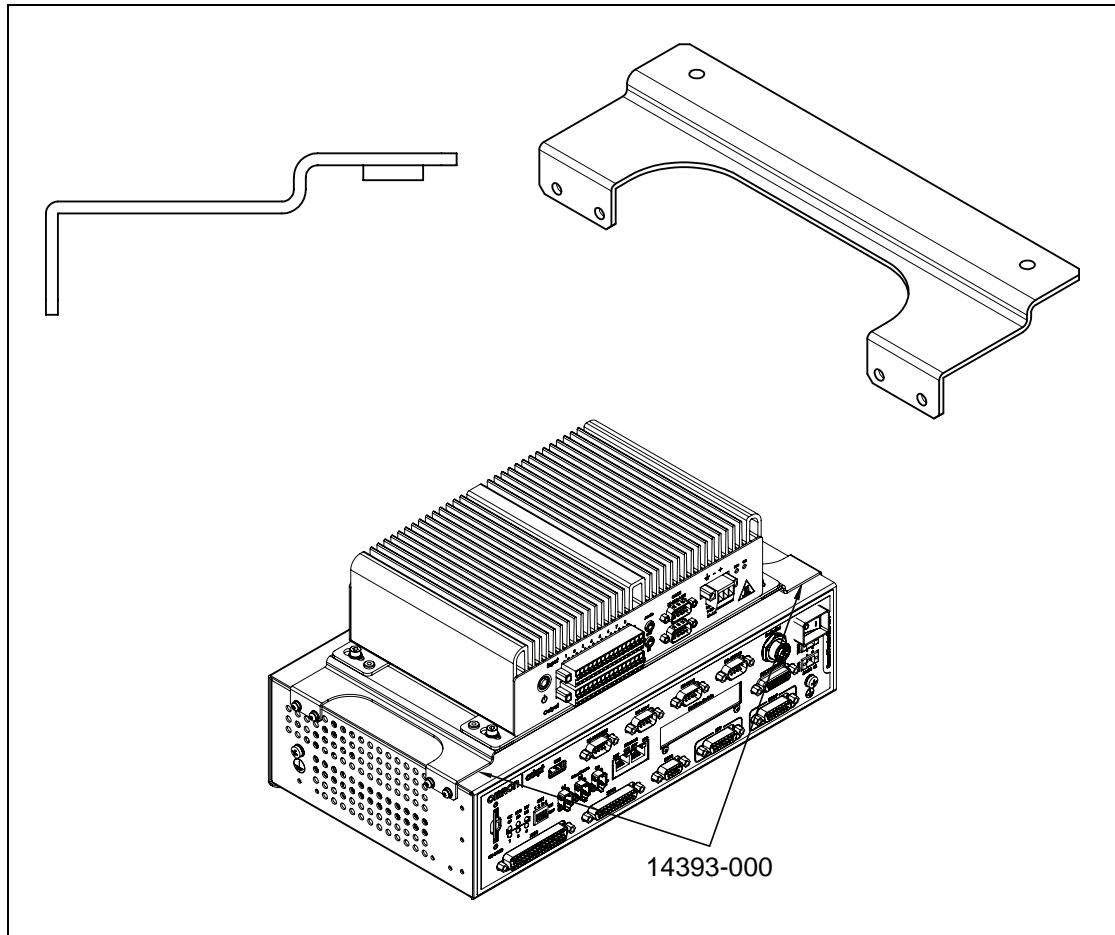

Figure 3-2. Views of SmartVision MX-SmartController Mounting Bracket

The mounting brackets are strictly a mechanical attachment. No electrical connections are involved.

1. Screw one bracket to each end of the SmartController motion controller.

Use four of each of these connectors for each bracket:

- M3x10 stainless socket-head cap screws
- M3 high-collar split lock washers
- M3 stainless flat washers

Tighten the M3 screws to 1.2 N·m (10.6 in-lbf).

There are two sets of two threaded holes on each side of the ventilation holes on the sides of the SmartController case. See the following figure.

2. Screw the SmartVision MX industrial PC to the top of the brackets, using the mounting tabs on the bottom of the SmartVision MX.

The SmartVision MX tabs go on top of the brackets.

Use two of each of these connectors at each bracket:

- M4x8 stainless socket-head cap screws
- M4 stainless split lock washers
- M4 stainless flat washers

Tighten the M4 screws to 4.6 N·m (40.7 in-lbf).

### 3.4 Connecting Power

Connect 24 VDC power to the input of the SmartVision MX.

#### External Power Supply

The SmartVision MX requires filtered 24 VDC power. It takes 4.2 A at 24 VDC.

**NOTE:** You must provide your own power supply. Make sure the power cables and power supply conform to the specifications in the following table.

*Table 3-1. Power Supply and Power Cable Specifications*

Customer-Supplied Power Supply	24 VDC (-10%, +5%), 150 W (6 A)
Circuit Protection	Not more than 8 A (below the amperage rating of the cable used)
Power Cabling	1.5 to 1.85 mm <sup>2</sup> (16 to 14 AWG), full-cover, braided shield cable, maximum length 10 meters
Shield Termination	Braided shield connected to the left wire slot of the VDC connector on the power side of the SmartVision MX. On the other end of the cable, the shield should be connected to the power supply chassis.



**CAUTION:** Make sure you select a 24 VDC power supply that meets the specifications in the preceding table. Using an underrated supply can cause system problems and prevent your equipment from operating correctly. See the following table for recommended power supplies.

**NOTE:** The power requirements for the user-supplied power supply will vary depending on the configuration of the SmartVision MX industrial PC and connected devices. A minimum configuration requires 3.0 A at 24 VDC. However, a 24 V, 6 A power supply is recommended to allow for additional current draw from connected external devices.

## Recommended Power Supplies

Table 3-2. Recommended Power Supplies

Vendor Name	Model	Ratings	Mount
OMRON	S8FS-G15024C	24 VDC, 6.5 A, 150 W	Side/Bottom
OMRON	S8FS-G15024CD	24 VDC, 6.5 A, 150 W	DIN-Rail Mount

## Recommended UPS Units

If power interruption is a concern, a UPS is recommended. The following table lists two recommended UPS units.

Table 3-3. Recommended UPS Units

Vendor Name	Model	Ratings
OMRON	S8BA-24D24D360LF	24 VDC, 15 A, 360 W
OMRON	S8BA-24D24D480LF	24 VDC, 20 A, 480 W

## Installing 24 VDC Connector

In order to maintain compliance with EN standards, DC power must be delivered over a shielded cable, with the shield connected to the frame ground at both ends of the cable. Conductors should be 1.5 to 1.85 mm<sup>2</sup> (16 to 14 AWG). The maximum length for the 24 VDC cable is 10 meters.

Use the supplied connector to connect the user-supplied 24 VDC power supply to the SmartVision MX.

1. Locate the 24 VDC connector that is shipped with the SmartVision MX industrial PC. See the following figure.
2. Strip 7 mm of insulation from the end of the wire that connects to the positive output of the 24 VDC supply.
3. Insert the stripped end of the wire into the opening on the right side of the connector.
4. Using a small, flat-blade screwdriver, tighten the screw clamp on the connector.
5. Inspect the connection to ensure that the clamp is on the wire, not on the insulation.
6. Gently pull on the wire to confirm that it is securely attached to the connector.
7. Repeat this process to connect the wire from the negative side of the power supply to the center of the connector.
8. Repeat this process to connect the braided shield to the left side of the connector.
9. Plug the connector into the SmartVision MX industrial PC.



Figure 3-3. DC Connector with Wires

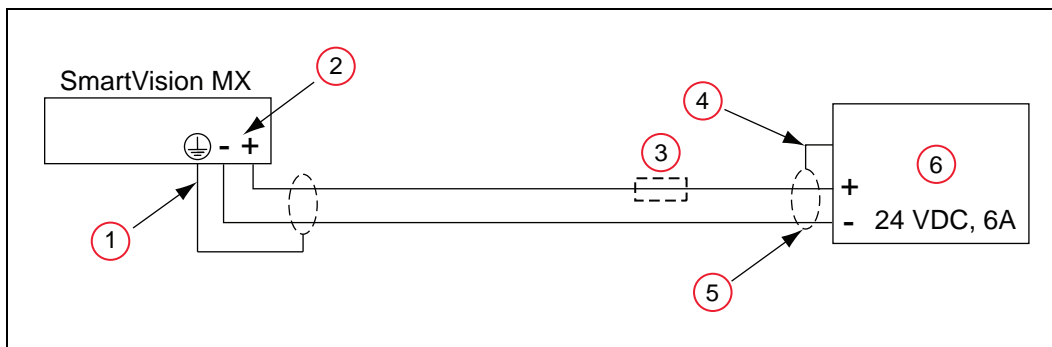

Figure 3-4. Ground for 24 VDC Cable Connections

Table 3-4. 24 VDC Cable Connection Descriptions

Item	Description
1	Attach shield from user-supplied cable to SmartVision MX using left wire slot in 24 VDC connector.
2	Use connector supplied at this end of cable.
3	Optional fuse.
4	Frame ground.
5	Attach shield from user-supplied cable to frame ground on power supply.
6	User-supplied power supply, circuit protection < 8 A.

### Connecting to a SmartController

The 24 VDC power cable is user-supplied.

1. Connect a 24 VDC cable from XDC1 or XDC2 on the controller (whichever is not used) to the 24 VDC connector on the SmartVision MX industrial PC.

2. Follow the instructions in the previous section for connecting VDC to the SmartVision MX industrial PC.

If your system has sDIO or sMI6, these need to be placed between the SmartController and the SmartVision MX industrial PC, so the power can be daisy-chained. The SmartVision MX industrial PC has only one 24 VDC plug. The other units have two.

If you are connecting peripherals to the SmartVision MX industrial PC, you may need to run a dedicated 24 VDC cable to the SmartVision MX industrial PC, rather than tapping power from the controller or your power supply. Make sure you are not exceeding the current capacity of the controller 24 VDC plug.

### **3.5 Connecting Display, Keyboard, and Mouse**

To connect a display to the SmartVision MX industrial PC, use either of the DVI- ports. If you have a VGA display, you will need to use the DVI-I port with a VGA adapter.

Connect your keyboard and mouse to USB ports.



# Chapter 4: Connectors and Indicators

The SmartVision MX, as shown in the following figures, can connect to many different peripherals. This section describes the connectors and indicators available.

## Camera Side

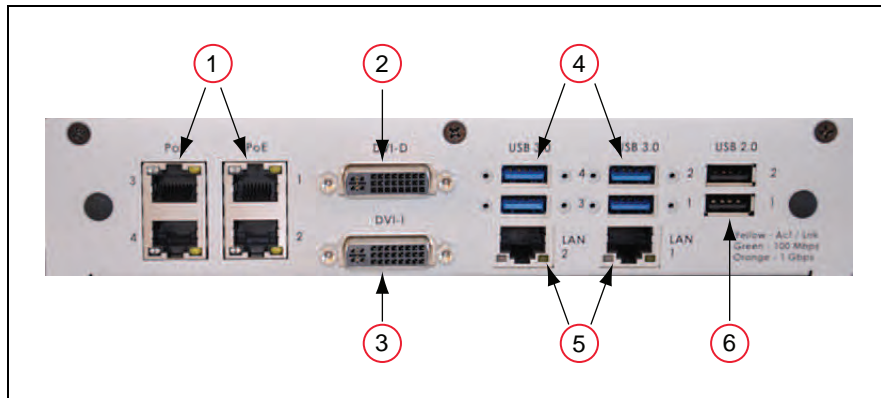

Figure 4-1. SmartVision MX Camera-side Connectors

Table 4-1. SmartVision MX Camera-side Connector Descriptions

Item	Quantity	Description
1	4	Gigabit Ethernet ports with Power Over Ethernet Ports (15.4 W max per port)
2	1	DVI-D Output Port
3	1	DVI-I Output Port
4	4	USB 3.0 Ports
5	2	Gigabit Ethernet Ports
6	2	USB 2.0 Ports

## Power/IO Side

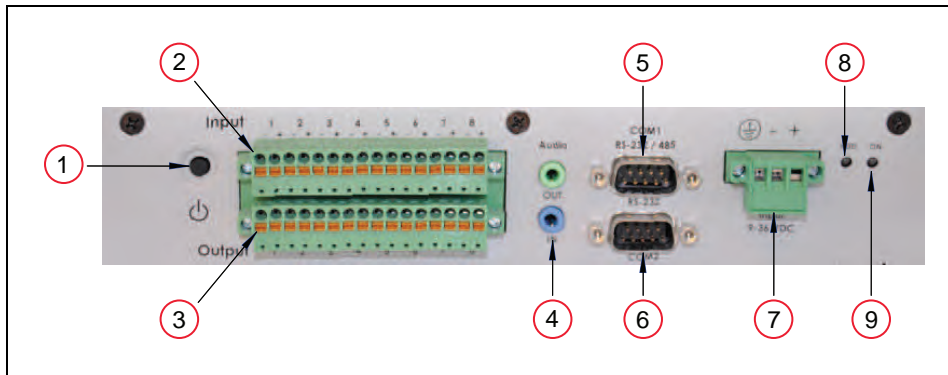

Figure 4-2. SmartVision MX Power-side Connectors

Table 4-2. SmartVision MX Power-side Connector Descriptions

Item	Description
1	Power Button
2	Not Supported
3	Not Supported
4	Audio In / Out Ports (not used by software)
5	RS232 / RS485 Port
6	RS232 Port
7	Power Input Connector (9 to 36 VDC nominal, 4.2 A @ 24 VDC)
8	HDD LED
9	Power ON LED



## 4.1 Ethernet Ports

Any of the Ethernet ports can be used to connect to Ethernet devices. Four of the ports provide Power over Ethernet, intended to provide the power needed for a GigE camera, though they can also be used as general-purpose Ethernet ports.

To attach the industrial PC to a network or broadband device, connect an Ethernet cable between the device and one of the Ethernet ports on the industrial PC.



**CAUTION:** It is not recommended that you connect the SmartVision MX directly to the internet for security reasons. If the industrial PC is directly exposed to the network, it could become vulnerable if not managed properly. If the SmartVision MX is on a LAN that has Internet access, make sure there is a firewall between the LAN and the Internet in order to prevent unwanted and unauthorized network traffic from reaching the SmartVision MX.

We recommend that you use Category 5 or better wiring and connectors for your network.

**NOTE:** If you are using a camera with a USB 2.0 connector or with an Ethernet connector that is not designed for PoE, you will need to provide DC power to the camera through a separate cable.

## 4.2 USB Ports

For a USB 3.0 camera, use one of the USB 3.0 ports.

To attach a USB peripheral, plug the peripheral cable into any one of the USB ports on the SmartVision MX industrial PC.

**NOTE:** The bottom-right USB 2.0 port is used for the license dongle, which is needed for the industrial PC to function. Do not remove the dongle.

## 4.3 DVI- Ports

To connect a monitor with a DVI connector:

- Connect the monitor to the DVI-I port on the SmartVision MX
- or
- Connect the monitor to the DVI-D port on the SmartVision MX.

Connecting a VGA monitor requires using the DVI-I port with a user-supplied VGA adapter.

## 4.4 Audio and Serial Ports

The Audio In, Audio Out, and the two RS232(/485) ports are fully functional, but are not used for vision processing.



## Chapter 5: Operation

---

This chapter describes how to operate the SmartVision MX. Before proceeding, you need to have performed the steps covered in the Installation chapter.

### 5.1 Operating Environment

- Ambient operating temperature: 0 to 50°C (32 to 122°F)
- Operating humidity: 10 to 90% (non-condensing)

### 5.2 Turning Power ON and OFF

The power button is a toggle. If the processor is on, pressing the button will turn it off. If the processor is off, pressing the button will turn it on.

The power button is on the power side of the processor, where 24 VDC is connected. When power is on, the ON LED will be lit.

### 5.3 Checking the Licenses on the Dongle

You can see what has been enabled on a dongle with the following procedure:

1. Turn on the SmartVision MX industrial PC and wait for it to finish booting.
2. Double-click the ACE icon on the desktop.
3. Select Create Example Workspace, then click Open.
4. Click **Help > Diagnostic Summary**.

ACE will display a list of all options that can be licensed by the dongle, and indicate which ones have been enabled.



# Chapter 6: Technical Specifications

## 6.1 Processor Specifications

Table 6-1. Processor Specifications

CPU	Intel® Core i7
PCH	Intel® HM76 Platform Controller Hub
Memory	8 GB DDR3
Operating System	Microsoft® Windows® Embedded Standard 7, 64 bit
Hard Drive	64 GB SSD

## 6.2 Environmental Specifications

The SmartVision MX must be shipped and stored in a temperature-controlled environment. Refer to the following table.

Table 6-2. Environmental Specifications

Ambient temperature	0 to 50°C (32 to 122°F)
Storage and shipment temperature	-25 to 55°C (-13 to 131°F)
Humidity range	10 to 90%, non-condensing

## 6.3 Power Requirements

Table 6-3. Power Specifications

Power Input	24 (-10%, +5%) VDC
Typical Power Consumption	4.2 A
Maximum Power Consumption	6.0 A at 24 VDC
Circuit Protection	Not more than 8 A

## 6.4 Dimensions

Table 6-4. SmartVision MX Dimensions

Width, including tabs	260 mm (10.24 inches)
Width, without tabs	225 mm (8.86 inches)
Depth, excluding connectors	150 mm (5.9 inches)
Height	68.1 mm (2.68 inches)

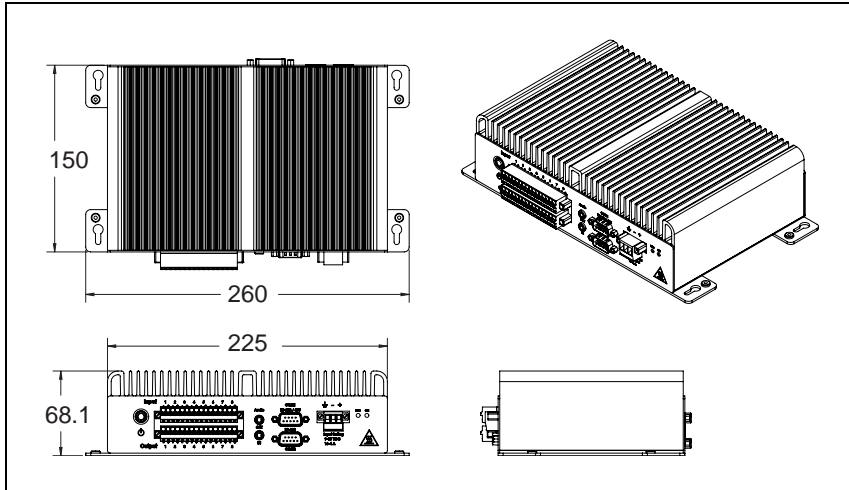

Figure 6-1. SmartVision MX Dimensions (Units in mm)

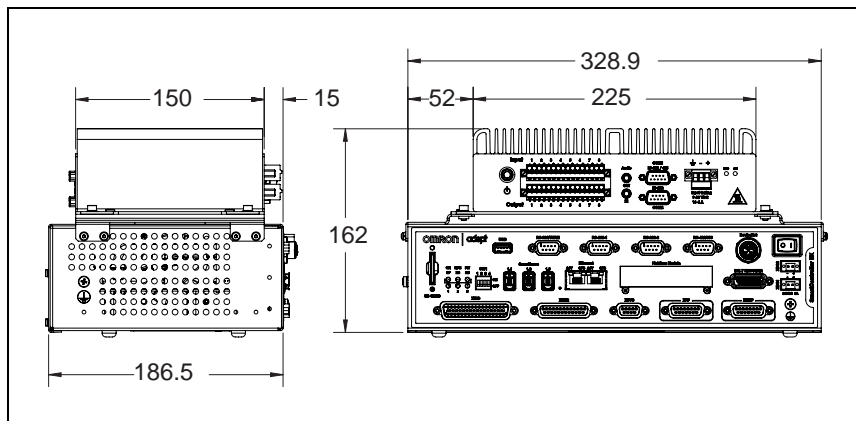

Figure 6-2. SmartVision MX Stack Mounted to SmartController EX (Units in mm)

## 6.5 Connections

- 10/100/1000 Ethernet x 6
  - 4 are PoE, up to 15.4 W/port
- USB 3.0 x 4
- USB 2.0 x 2
  - One of these is used for the license dongle.
- DVI-D output
- DVI-I output
- RS232/RS485 port
- RS232 port
- Digital I/O (not supported)

## 6.6 Camera Specifications

The following table provides specifications for camera variations that are compatible with the SmartVision MX.

Table 6-5. Camera Variations

Model	24114-101	24114-200	24114-201	24114-250	24114-251	24114-300	24114-301
Image Elements	1/4-inch CCD	1/3-inch CCD	1/3-inch CCD	1/1.8-inch CMOS	1/1.8-inch CMOS	1-inch CMOS	1-inch CMOS
Effective Pixels (H x V)	658 x 492	1296 x 966	1294 x 964	1602 x 1202	1600 x 1200	2048 x 2048	2046 x 2046
Color / Mono-chrome	Color	Mono-chrome	Color	Mono-chrome	Color	Mono-chrome	Color
Frame Rate	120 fps	30 fps	30 fps	60 fps	60 fps	25 fps	25 fps
Trigger input	Software / External			Software	Software / External		
Interface	Gigabit Ethernet (1 Gbit/s)						
Lens Mounting	C mount / CS mount			C mount	C mount / CS mount	C mount	
Power Supply Voltage	PoE or 12 VDC						
Power Consumption (PoE / AUX)	2.5 W / 2.0 W	2.7 W / 2.2 W		2.7 W / 2.1 W		3.1 W / 2.6 W	
Weight	Approximately 90 g						
Bundled Cables	Camera Cable, 10 m (14359-000) Power I/O Cable, 10 m (09454-610)						



# Chapter 7: Options

## 7.1 License Options

There are several different license requirements that are based on the software type and ACE version. Use the table below to understand the different software license compatibility options.

Refer to Chapter 1: Introduction for USB license dongle information.

### Software License Details

Table 7-1. Software License Compatibility

Software	Licensing for ACE 3.6 or Earlier	Licensing for ACE 3.7.3.200 or Later
ACE PackXpert with AdeptSight	Includes ACE PackXpert and AdeptSight 3.0	Includes ACE PackXpert and AdeptSight 3.0
ACE PackXpert	License Required	License Required
AdeptSight 3.0	License Required	License Required
Additional Camera (standard)	License Required	Not Applicable
Additional Camera (color)	License Required	Not Applicable
ACE Controller	License Required	Not Applicable
OPC Server	License Required	Not Applicable
OPC Client	License Required	Not Applicable
UI Builder Option	License Required	Not Applicable
Emulator	Not Applicable	Not Applicable

## 7.2 Mounting Options

The SmartVision MX industrial PC can be ordered with brackets that let the user mount the industrial PC on top of a SmartController motion controller.

### Mounting Kits

The following mounting kit is available (order separately).

*Table 7-2. Mounting Kit Details*

<b>Item</b>	<b>Part Number</b>	<b>Contents</b>
Mounting Bracket Kit	14391-000	<ul style="list-style-type: none"><li>• Bracket: 2 x 14393-000</li><li>• M4 flat washer: 4 x 54000-96700</li><li>• M4 lock washer: 4 x 54100-96700</li><li>• M4x8 screw: 4 x 09664-008</li><li>• M3 lock washer: 8 x 00782-000</li><li>• M3x10 screw: 8 x 51020-65010</li><li>• M3 flat washer: 8 x 54000-96500</li></ul>



**OMRON Corporation Industrial Automation Company**

Kyoto, JAPAN

Contact: [industrial.omron.eu](http://industrial.omron.eu)

**Regional Headquarters**

**OMRON EUROPE B.V.**

Wegalaan 67-69, 2132 JD Hoofddorp  
The Netherlands  
Tel: (31)2356-81-300/Fax: (31)2356-81-388

**OMRON ELECTRONICS LLC**

2895 Greenspoint Parkway, Suite 200 Hoffman Estates,  
IL 60169 U.S.A.  
Tel: (1) 847-843-7900/Fax: (1) 847-843-7787

**OMRON ASIA PACIFIC PTE. LTD.**

No. 438A Alexandra Road # 05-05/08 (Lobby 2),  
Alexandra Technopark,  
Singapore 119967  
Tel: (65) 6835-3011/Fax: (65) 6835-2711

**OMRON ADEPT TECHNOLOGIES, INC.**

4550 Norris Canyon Road, Suite 150, San Ramon, CA 94583 U.S.A.  
Tel: (1) 925-245-3400/Fax: (1) 925-960-0590

**OMRON (CHINA) CO., LTD.**

Room 2211, Bank of China Tower, 200 Yin Cheng Zhong Road,  
PuDong New Area, Shanghai, 200120, China  
Tel: (86) 21-5037-2222/Fax: (86) 21-5037-2200

Authorized Distributor:

© OMRON Corporation 2019 All Rights Reserved.  
In the interest of product improvement,  
specifications are subject to change without notice.

Cat. No. I608-E-03

Printed in USA  
0319 (0416)

14362-000 D